



A Public Agency

RETHINKWASTE BOARD OF DIRECTORS MEETING

THURSDAY, FEBRUARY 27, 2025 at 2:00 p.m.

RethinkWaste Administrative Offices
1245 San Carlos Ave. Suite E
San Carlos, CA 94070

The public may observe/participate in Board meetings using remote public comment options or attending in person. Board members shall attend in person unless remote participation is permitted by law.

TO ADDRESS THE BOARD IN PERSON

Masking is not required but according to the California Department of Public Health guidelines, people at higher risk for severe illness should consider masking. To help maintain public health and safety, we respectfully request that people NOT attend in-person if they are experiencing symptoms associated with COVID-19 or are otherwise ill and likely contagious (e.g., respiratory illnesses).

To address the Board on any item – whether on the posted agenda or not – please fill out a Request to Speak Form and submit it to the Board Clerk. Speakers are not required to submit their name or address.

REMOTE PARTICIPATION

Members of the public may participate in public Agency meetings by logging into the Zoom:

<https://us02web.zoom.us/j/83901572317?pwd=HG8B80eM8xd2dZSPGZBZEaVhpalvhM.1>

Meeting ID: 839 0157 2317

Passcode: 743977

Written public comments for the record may be submitted in advance by 12:00 p.m. on the meeting date by email to: rethinker@rethinkwaste.org and will be made part of the written record but will not be read verbally at the meeting. Written public comments submitted by email should adhere to the following: 1) Clearly indicate the Agenda Item No. or specify “Public” in the Subject Line for items not on the agenda and 2) Include the submitter’s full name. You may also use the raise hand feature on Zoom to enter a “live” verbal public comment.

*Pursuant to Ralph M. Brown Act, government code section 54953, all votes shall be by roll call if any members of the board of directors are participating by teleconference and/or video conference.

AGENDA

1. Call to Order/Roll Call
2. Public Comment

Persons wishing to address the Board on matters NOT on the posted agenda may do so. Each speaker is limited to three minutes. If there are more than five individuals wishing to speak during public comment, the Chairman will draw five speaker cards from those submitted to speak during this time. The balance of the Public Comment speakers will be called upon at the end of the Board Meeting. If the item you are speaking on is not listed on the agenda, please be advised that the Board may briefly respond to statements made or questions posed as allowed under The Brown Act (Government Code Section 54954.2). The Board's general policy is to refer items to staff for attention, or have a matter placed on a future Board agenda for a more comprehensive action or report and formal public discussion and input at that time. *Speakers may also submit comments via email prior to the meeting by sending those comments to rethinker@rethinkwaste.org.*

MEMBER AGENCIES

BELMONT * BURLINGAME * EAST PALO ALTO * FOSTER CITY * HILLSBOROUGH * MENLO PARK * REDWOOD CITY
* SAN CARLOS * SAN MATEO * COUNTY OF SAN MATEO * WEST BAY SANITARY DISTRICT
FULL PACKET PAGE 1 of 123

February 20, 2025

- 3. Executive Director’s Report** p. 5
- 4. Approval of Consent Calendar**
 Consent Calendar item(s) are considered to be routine and will be enacted by one motion. There will be no separate discussion on these items unless members of the Board, staff or public request specific items be removed for separate action. *Items removed from the Consent Calendar will be moved to the end of the agenda for separate discussion.*
- A. Approval of the Minutes from the November 21, 2024 Board of Directors Meeting ACTION p. 13
 - B. Resolution Approving the Appointment of former Board Member Al Roysse as a Citizen At Large member of the Finance Committee for a one-year term ACTION p. 19
 - C. Resolution Authorizing the Material Recovery Facility (MRF) Harris Baler Refurbishment Project at a Not to Exceed amount of \$184,475 ACTION p. 23
 - D. Approval of the Quarterly Investment Report for the Quarter Ending December 31, 2024 ACTION p. 35
- 5. Administration and Finance**
- A. Election of RethinkWaste Board of Director’s Chair and Vice Chair for 2025 ACTION p. 43
 - B. Resolution Approving 2025 RethinkWaste Committee Appointments ACTION p. 45
- 6. Collection and Recycling Program Support and Compliance**
 No Items
- 7. Shoreway Operations and Contract Management**
- A. Resolution Authorizing the Payment of \$357,191.18 to SBI for the Replacement of the Material Recovery Facility (MRF) Screen Disks ACTION p. 51
- 8. Public Education, Outreach and Legislation**
- A. Resolution Approving the 2025-2026 Legislative and Regulatory Platform ACTION p. 63
- 9. Informational Items Only (no action required)**
- A. 2025 Legislative and Regulatory Update p. 73
 - B. Update on SB 1383 Compliance Program on behalf of RethinkWaste Member Agencies p. 93
 - C. 2025 Finance and Rate Setting Calendar p. 97
 - D. Check Register Detail for November – December 2024 p. 99
 - E. Technical Consulting Contracts Issued June 2024-December 2024 p. 117
 - F. 2025 Meeting Planning Guide p. 121
- 10. Board Member Comments**
- 11. Adjourn**

**NEXT MEETING: RethinkWaste Board Members and TAC members Retreat at the Belmont Sports Complex
 12N to 4PM**



A Public Agency

EXECUTIVE DIRECTOR'S REPORT

STAFF REPORT

To: RethinkWaste Board Members
From: Joe La Mariana, Executive Director
Date: February 27, 2025 Board of Directors Meeting
Subject: Executive Director's Report

Staff and agency partners continue to be hard at work supporting a variety of projects, programs, and facility initiatives. Here are the highlights:

1. Administration & Finance:

a. Green Business Certification

As of January 17, 2025, the RethinkWaste administrative office is certified as a Tier 1 Entry-level San Mateo County and California Green Business. Tier 1 is the first step of the Green Business Program and focuses on saving us money on water and energy while also protecting the environment. Thank you to Public Outreach Fellow Lina Pietrzyk for your work in getting us to this first step!

b. Press Conference for Co-Sponsored Legislation - AB 762

On February 19, I had the pleasure of speaking with Asm. Irwin and co-sponsors about AB 762, which will ban single-use disposable vapes. RethinkWaste, along with Californians Against Waste, California Product Stewardship Council and CALPIRG (California Public Interest Research Groups) are co-sponsoring this important legislation. This bill is a follow-up to our battery bills from 2022 that were signed by the Governor to fill a gap on how these single-use devices pose a serious threat to facilities with their embedded lithium-ion batteries and are incredibly difficult to recycle.



I am mentioned in an article in the Sacramento Bee about the press conference for the bill: <https://www.sacbee.com/news/politics-government/capitol-alert/article300590274.html>

More information about our legislative work with our lobbyists is under agenda item 9A.

c. **Get to Know RethinkWaste – Successful Orientation, One more on Feb 26!**

On February 6th, RethinkWaste hosted an orientation session for RethinkWaste service area newly elected council members an/or new RethinkWaste Board Members. It was attended by Laurie Davies Adams (Hillsborough); Supervisor Ray Mueller (San Mateo County) and Pheobe Venkat (Foster City). After working lunch presentations by our agency’s senior staff and our contracting partners, John Zirelli (Recology) and Dwight Herring (SBI), we went to the Shoreway Environmental Center for a walking tour of the site. We had an engaging afternoon engaging with our new friends!



A second orientation session will be held on February 26th—contact Dolores Molina-Bucio at dmolina.bucio@rethinkwaste.org to reserve your spot—we’d love to have you join us if you can! This is a great way to be introduced to our agency’s mission and team and learn what we do and why we do it. Lunch will be provided.

d. **RethinkWaste Committees looking for new members**

With the large turnover on the RethinkWaste Board of Directors this year, there are a few vacancies that will need to be filled in today’s meeting under agenda item 5B. Please contact myself or Cyndi to express your interest in serving.

2. **Committee Updates:**

a. **Finance Committee Meeting** (no meeting)

b. **Legislative Committee** (next meeting is March 4)

c. **Pub Ed/Outreach Committee** (no meeting)

d. **Technical Advisory Committee** (February 13)

The TAC elected a new chair, Jack Johnson (San Mateo). Previous chair ‘Andra Lorenz (Foster City) is retiring later this spring. TAC Vice Chair Adrian Lee (Redwood City) was re-elected as Vice Chair. TAC members received a presentation from RethinkWaste staff about the problem of single-use foodware at schools and a possible future consideration to assist schools to move to reusable foodware through a pilot grant program. TAC also received updates about current SB 1383 happenings, including a presentation from Recology, and discussed MFD waivers and the NOV mailing schedule for 2025.

e. **Zero Waste Committee** (no meeting)

3. **Collection and Recycling Program Support and Compliance:**

a. **SB 1383 Update**

RethinkWaste Staff and Recology continue to contact all commercial and multi-family generators that applied for SB 1383 waivers. In January 2025, staff sent 30 SB 1383 waiver decision letters to generators that applied (service area wide). Of that, 23 were approval letters, and 7 were denial letters. Staff conducted two SB 1383 compliance presentations since the beginning of the year, first to the Downtown San Mateo Association (DSMA), and second to the City of Burlingame's Economic Development Subcommittee. Topics covered included SB 1383 requirements, proper sorting techniques, container cleanliness techniques, how to comply with SB 1383, how to sign up for De Minimis and Physical Space Waivers, and who to contact for further assistance.

More information about SB 1383 implementation can be found in agenda item 9B.

b. Community Outreach and Environmental Education

i. **Outreach Updates**

An electronic newsletter went out in February to promote shred and e-scrap events, recycling tips, and safe battery disposal. Presentations for the year have begun, with staff kicking off the year presenting at Burlingame's Economic Development Subcommittee alongside San Mateo County Mosquito and Vector Control and Recology San Mateo County, followed by a presentation to San Mateo apartment/condominium residents about proper sorting and the services RethinkWaste offers. Event planning for the year is in full swing, with staff planning Earth Day tours in April, tabling events within our service area, and a SB 1383 summit to promote composting among apartment/condominium residents and property managers.

ii. **Shoreway Tours Program**

Over the past month, the team hosted five large tours for elementary-aged students from Foster City Elementary (Foster City) and Laurel Elementary (Menlo Park). College students from Cañada College (Redwood City) also visited the Shoreway Environmental Center, along with members of the public as part of the monthly in-person and virtual public tours. Monitors in the Education Center 2nd floor hallway leading to the Rethinker Room are up and running, playing video tours of our recycling partners' facilities for attendees to watch while passing by.

iii. **In-Schools Program Update**

In late January, the Environmental Education (EE) Team completed a successful program rollout at North School Elementary (Hillsborough). This is the first program rollout the EE Team has implemented at a school in Hillsborough. Additionally, the team provided refresher education to McKinley Elementary (Burlingame) in mid-February. Both the rollout and the refresher included campus-wide assemblies about proper sorting practices and lunch bin monitoring to provide extra support to students. North School also received new equipment including color-coordinated waste bins and signage.

The EE Team also supports schools' green team efforts. Green teams are typically composed of school staff, parent volunteers, and students who meet regularly to collaborate on sustainability-related projects. In January and February, the EE Team attended two green team trainings to provide extra education to these groups and troubleshoot the unique waste-related issues they are facing on their campuses.

iv. **2024 Poster Contest winner truck reveal**

This winter, the team coordinated and unveiled the Recology trucks featuring artwork from both Poster Contest winners. Both first place winners from Menlo Park and San Mateo had the opportunity to see the truck and take photos with it along with their families and classmates. These photo ops met with a lot of enthusiasm! Contest winners from Bemont and San Mateo were also honored at City Council Meetings at the end of January.



Arielle H., Middle School winner from La Entrada Middle School, Menlo Park



Melissa J, Elementary School winner from Baywood Elementary, San Mateo

4. Shoreway Operations and Capital Projects

a. **Underground Fuel Storage Tank Replacement Project**

As of February 5, 2025, the Underground Fuel Storage Tank (UST) Replacement Project has achieved substantial completion. By contract, the contractor is allowed sixty (60) days to complete all punch list items and closeout documentation. The project final completion date is April 5, 2025. The UST and fuel dispensing system is currently in use by Recology and



SBI. The new system is fully compliant with the California Senate Bill 445 that requires the removal of all single-walled UST by December 31, 2025.

The scope of the project was to remove and replace the three existing single-walled 12,000 gallon USTs and the fuel dispensing system consisting of 4 fuel dispensers on a main fuel island, and one remote fuel dispenser. The project included demolition, removal, and replacement of asphalt, concrete pads, concrete curbs, replacement single-walled USTs with double walled USTs, and ancillary utilities such as Diesel Emission Fluid (DEF) and Waste Oil Tables.

Contract for the UST Replacement Project was awarded to CIC Construction on July 13, 2023 with the following proposal cost and contingency allowance:

CIC Proposal:	\$2,423,964
Contingency Allowed:	<u>\$ 422,489</u>

Total Contract With Contingency: \$2,846,453

Total construction costs came in under budget by \$311,369 approximately 15% lower than anticipated. The project had a total of four (4) change orders with Change Order#001 – Additional Dewatering Costs costing \$304,528. Other change orders included modifications to the waste oil system, upgrading the remote fuel island with a twin dispenser, and making additional modifications to the dewatering system. Other professional services and fees for this project included geotechnical, chemical analysis, concrete inspection services, and City discharge fees. Many thanks to project manager Hilary Gans for his skilled management of these various technical partners to achieve such a positive outcome. Nice work!

Additional thanks to Recology and SBI for their supreme flexibility while conducting their daily operations while this disruptive work was going around them. I emphatically state...we're all glad this work is DONE.

b. FEMA Severe Winter Storms Public Assistance Grant Update

Back on the weekend of January 1, 2023, the agency-owned Shoreway Environmental Center (SEC) sustained damage to multiple locations on the site due to extreme flooding, most notably to the Transfer Station tunnel and the Recology administration building located at 225 Shoreway Road. The total cost related to the flood damage was \$195,326. Staff successfully applied for emergency-related funding assistance from the Federal Emergency Management Agency (FEMA) Public Assistance Program. FEMA, along with the California Governor's Office of Emergency Services (Cal OES), will reimburse the agency a total of \$189,876, of which \$180,874 has recently been received. RethinkWaste will be responsible for only \$5,451 of the total cost of damages. Thank you to Associate Engineer Joanne Nghiem for working on this multi-year project to get the funds.

5. Contractor Updates:

a. Recology San Mateo County (Recology)

Recology Collected and 691 tons of Christmas trees during the holiday period

On January 13, 2025, the California Air Resource Board (CARB) withdrew its request for an Environmental Protection Agency (EPA) waiver to enforce the Advance Clean Fleet regulation that would require Recology to start phasing in Zero Emission trucks starting in 2027-2031. Recology is currently evaluating what types of vehicles are available to operate in California and replace the remaining fleet in 2026-2027

Completed the 225 Shoreway Road office defective flooring replacement as a result of the January 1, 2023 flood due to drainage issues on Shoreway Road. Recology and RethinkWaste is working with the four jurisdictions of San Carlos, Redwood City, Belmont and the County of San Mateo to resolve this problem. During the last three major rains, office staff cannot access the facility due to the flooding of the street and parking lots

General Manager John Zirelli will be retiring in June after 49 years in the industry and 27+ years at the 225 and 333 Shoreway site. Also, Mia Rossi, Recology Community Relations Manager and Sandra Herrera, Customer Service Manager have been promoted to positions at the corporate office and Recology is currently interviewing for all three (3) positions

b. South Bayside Industries (SBI) operations

SBI took delivery of its EV Roll-Off this past week. This is a Peterbilt 520EV, which will be used on-site to move our 20- and 50-yard roll-off boxes between PRC and the MRF. As of this email, this unit is at ARATA Equipment company having some safety equipment installed and will be operational as of February 24th. SBI roll-off driver, mechanic as well as myself, Chris Valbusa, and SBIs Operations Manger and Maintenance supervisor were provided an orientation on the equipment by the Peterbilt representative last week. Great technical leadership SBI!

The FIKE automated fire suppression system has been installed in the MRF, and the Fire Marshall was at Shoreway today testing the equipment and signed off that it is in good operating condition. This equipment will provide automated fire suppression during operating and non-operating hours at the MRF. The system is designed to recognize a heat source generating from the loose commingled recyclables on the MRF tip floor, extinguishing any heat source or fire that may erupt due to a damaged lithium-ion battery or other heat source.

SBIs management team continues to conduct in depth facility inspections and records any areas (large or small) that may need attention. These deficiencies are recorded, a project is created, and manpower is assigned, and management follows up to ensure the deferred maintenance has been completed correctly. Most of the larger projects have been completed, however, we continue to be diligent to ensure even the smaller areas that need attention are properly addressed.

Respectfully submitted,



Joe La Mariana
Executive Director



A Public Agency

CONSENT CALENDAR

DRAFT MINUTES
RETHINKWASTE
SOUTH BAYSIDE WASTE MANAGEMENT AUTHORITY
MEETING OF THE BOARD OF DIRECTORS
 November 21, 2024– 2:00 p.m.
 RethinkWaste Administrative Offices
 1245 San Carlos, Ave. Suite E San Carlos, CA 94070

Call to Order: 2:00 PM

1. Call to Order/Roll Call

Agency	Present	Absent	Agency	Present	Absent
Belmont	X		Redwood City	X	
Burlingame	X		San Carlos	X	
East Palo Alto	X		San Mateo	X	
Foster City	X		County of San Mateo		X
Hillsborough	X		West Bay Sanitary District	X	
Menlo Park	X				

George Otte Attended as an alternate Board Member for West Bay Sanitary District

2. Public Comment

Persons wishing to address the Board on matters NOT on the posted agenda may do so. Each speaker is limited to three minutes. If there are more than five individuals wishing to speak during public comment, the Chairman will draw five speaker cards from those submitted to speak during this time. The balance of the Public Comment speakers will be called upon at the end of the Board Meeting. If the item you are speaking on is not listed on the agenda, please be advised that the Board may briefly respond to statements made or questions posed as allowed under The Brown Act (Government Code Section 54954.2). The Board's general policy is to refer items to staff for attention, or have a matter placed on a future Board agenda for a more comprehensive action or report and formal public discussion and input at that time. *Speakers may also submit comments via email prior to the meeting by sending those comments to rethinker@rethinkwaste.org.*

None

3. Executive Director's Report

Executive Director La Mariana thanked the Board for their support of the new administrative office space and made the following announcements.

- On December 3 there will be a Legislative Committee meeting, and there will be a vacancy on that committee in 2025.
- At the January Board meeting there will be elections for the 2025 Board Chair and Vice Chair as well as a study session on planning for Zero Emission Vehicles.
- The Board meeting will be in March and the site long term forecasting will be a large part of that discussion.
- February 13th and 26th will be a newly elected official orientation not only for the new board members, but also for any new elected members in our service area.
- A letter has been sent to County Manager Mike Callagy formalizing the Agency's interest in gaining

access to a long-term lease of 3-4 acres of County land at the airport.

- The Fike Water Cannon has been installed at the MRF and we are awaiting for Fire Marshall sign off. He noted that staff may be coming to the Board after a sufficient testing period in the MRF to do the same system in the transfer station.
- There was a meeting on Monday to hold a public hearing at the County to expand the Shoreway operations to 24 hours. There were no protests at the hearing.
- During January there will be tree recycling available curbside, that means there will be no Bulky Item Collections available in January as the same crews will be collecting trees.
- He will be attending the Member Agency's council meetings during December for their reorganization meetings.
- The Recology administration team will be working from home as the floor is repaired in their offices at 225 Shoreway. This work is provided at no charge due to faulty installation.
- He gave thanks and recognition to Board Members Alicia Aguirre (Redwood City), Al Royse (Hillsborough) and Jon Froomin (Foster City) for their extraordinary service to the Agency.

Chair Rak thanked the three retiring board members and presented them with gifts of thanks.

4. Approval of Consent Calendar

Consent Calendar item(s) are considered to be routine and will be enacted by one motion. There will be no separate discussion on these items unless members of the Board, staff or public request specific items be removed for separate action. *Items removed from the Consent Calendar will be moved to the end of the agenda for separate discussion.*

- Approval of the Minutes from the October 24, 2024 Board of Directors Meeting
- Approval of the 2025 RethinkWaste Board of Directors and Brown Act Committee Meeting Calendars
- Approval of Quarterly Investment Report for the Quarter Ended June 30, 2024

Motion/Second: Froomin/Romero

Voice Vote: All in favor 10-0-0-1

Agency	Yes	No	Abstain	Absent	Agency	Yes	No	Abstain	Absent
Belmont	X				Redwood City	X			
Burlingame	X				San Carlos	X			
East Palo Alto	X				San Mateo	X			
Foster City	X				County of San Mateo				X
Hillsborough	X				West Bay Sanitary Dist.	X			
Menlo Park	X								

5. Administration and Finance

- Resolution Approving a 7th Amendment to the Executive Director's Employment Agreement

Counsel Savaree noted that the Board completed a performance evaluation for the Executive Director, and this was an amendment to the contract to increase the salary by 3%.

Motion/Second: Royse/Brownrigg

Voice Vote: All in favor 10-0-0-1

Agency	Yes	No	Abstain	Absent	Agency	Yes	No	Abstain	Absent
Belmont	X				Redwood City	X			
Burlingame	X				San Carlos	X			
East Palo Alto	X				San Mateo	X			
Foster City	X				County of San Mateo				X
Hillsborough	X				West Bay Sanitary Dist.	X			
Menlo Park	X								

B. Resolution Approving the RethinkWaste 2025-2034 Long Range Plan

Staff Nghiem presented the final RethinkWaste 2025-2034 Long Range Plan, and gave a review of the timeline, the new proposed mission statement, vision statement, guiding principles and goals.

Member Aguirre noted that the guiding principles were good but there were a lot of them, they feel like goals, but they are hard to measure, so look at it again to make sure the guiding principles are not goals.

Staff Nghiem noted that if the guiding principles were renamed goals they would need to be measured, a principle is more of a motivation or standard.

Member Aguirre asked what other organizations call something similar.

Staff Nghiem answered that it's generally called values.

Member Royse commented that he thought principles are the lens to look through when making decisions and looking at it that way he thought these were principles.

Member Loraine thought the guiding principles were a detailed explanation of ways to pursue the mission.

The Board decided to leave the guiding principles as is, but Member Royse suggested that in an appendix the term guiding principles is defined.

The Board then discussed the Goals section of the Long Range Plan.

Member Loraine recalled that legislative advocacy goals were a part of each of the goals but noted that it's only called out in the subtext of goal A, but not mentioned in the other sections' goals.

Staff Joanne noted that in the other sections it's listed by the specific bill number.

Member Loraine suggested adding a guiding principle relating to advocacy so that it's overarching to all the work.

The board recommended removing the zero waste principle because it's our vision, and therefore repetitive and replace with advocacy.

Vice Chair Brownrigg asked how the Agency plans to use this document as a tool.

Executive Director La Mariana noted that there would be deep dive check-ins in year 3 and 6, and then an annual check in at the retreat each year.

The Board acknowledged Staff Nghiem for her work in creating this document.

Member Aguirre made a motion to approve the Long Range Plan with the changes discussed.

Motion/Second: Aguirre/Froomin

Voice Vote: All in favor 10-0-0-1

Agency	Yes	No	Abstain	Absent	Agency	Yes	No	Abstain	Absent
Belmont	X				Redwood City	X			

Burlingame	X				San Carlos	X			
East Palo Alto	X				San Mateo	X			
Foster City	X				County of San Mateo				X
Hillsborough	X				West Bay Sanitary Dist.	X			
Menlo Park	X								

C. Resolution Approving the FY2025 Operating Budget and Capital Improvement Plan

Staff Mangini gave a PowerPoint presentation on the final version of the 2025 budget and highlighting the few changes since the October study session.

Member Royse commented not related to the passing of the budget but asked staff not to lose site of the fact that there was a request to the Finance Committee or a special committee to address a comprehensive approach and analytics for replenishing reserves.

Member Romero suggested having a consultant take a comprehensive approach and develop a schedule to replenish the reserves.

Chair Rak suggested a Finance Committee meeting before the two members rotate off so the board can take action early next year.

Member Loraine suggested integrating the discussion regarding capital planning into this planning.

Chair Rak suggested having a January agenda item to approve funds for a consultant and replenish the vacant Finance Committee members.

Member Brownrigg suggested that staff do a bit more work to get to a clear scope of work for a consultant before the consultant is hired.

Member Froomin suggested reaching out to the Member Agencies Finance Directors to get best practices.

The Finance Committee decided to attempt a meeting between December 3rd through 5th, to discuss this topic and scope and give direction staff on a path forward.

Motion/Second: Royse Loraine

Voice Vote: All in favor 10-0-0-1

Agency	Yes	No	Abstain	Absent	Agency	Yes	No	Abstain	Absent
Belmont	X				Redwood City	X			
Burlingame	X				San Carlos	X			
East Palo Alto	X				San Mateo	X			
Foster City	X				County of San Mateo				X
Hillsborough	X				West Bay Sanitary Dist.	X			
Menlo Park	X								

D. Report From Board Subcommittee Regarding San Carlos Host Fee and Request to Appoint New Members To The Subcommittee

Vice Chair Brownrigg gave background information on why this issue has been brought to the board, and the history of how the host fee is determined. He noted that over the last 10 years, the gate fees have doubled, but the volume has only grown by 11%, but because the host fee is determined based on total revenue, the gate fees have also doubled, which doesn't feel commensurate with the impacts to the city. So, the first

question before the board today, is whether the Board is comfortable asking San Carlos to renegotiate the host fee. He noted that just asking for San Carlos to reduce the host fee is not likely to be successful. So, the committee determined an alternative solution could be a fixed fee based on volume per city similar to a membership fee that would then reduce gate fees and thereby reduce the host fee. The second question before the board is would the board like to renew the committee and give them time to determine the methodology for this fee-based system that would reduce the host fee. And then the direction to negotiate with San Carlos before going down the path of the alternate fee structure.

Member Froomin commented as a member of committee that the alternative is just that an alternative, the goal would be to sit down with the city and renegotiate based on the most recent 34% increase this is the right time.

Member Royse commented as a member of the committee that he is more concerned about the increases in the next 3-7 years not being commensurate with the impact on the city.

Member Nash asked what the length of the contract is, and how long is the commitment to have a facility at that site.

Counsel Savaree answered that the JPA owns the land and the host fee was imposed as part of a conditional use permit and is an evergreen contract.

Member Aguirre commented that she'd like to see this continue to move forward.

Chair Rak asked staff and committee members to think through a minimum, and the intangible impacts on the residents of San Carlos.

Member Froomin commented that the committee never discussed a drastic reduction but wanted to focus on the escalation clause going forward.

Member Loraine asked what the next steps would be, and how would the subcommittee continue to work on this. He also volunteered to be on the committee.

Member Brownrigg answered that staff would flesh out the plan for alternative billing, and the committee would meet one more time to review that plan before it came to the board. Then the board would approve presenting the alternate billing plan as an option to San Carlos to see how those talks go.

Members Romero and Loraine will join Vice Chair Brownrigg on the committee and continue this work and will direct staff to develop an alternative fee schedule framework, and give authority to the committee to meet with San Carlos.

Motion/Second: McCune/Froomin

Voice Vote: 9-0-1-1

Agency	Yes	No	Abstain	Absent	Agency	Yes	No	Abstain	Absent
Belmont	X				Redwood City	X			
Burlingame	X				San Carlos			X	
East Palo Alto	X				San Mateo	X			
Foster City	X				County of San Mateo				X
Hillsborough	X				West Bay Sanitary Dist.	X			
Menlo Park	X								

6. Collection and Recycling Program Support and Compliance

No Items

7. Shoreway Operations and Contract Management

No Items

8. Public Education, Outreach and Legislation

- A. 2024 Legislative Session Recap and Resolution Approving a 2-Year Contract with Environmental and Energy Consulting (EEC) for a not to exceed amount of \$156,000 for Legislative Policy Advocate Consulting

Staff Au introduced the item and introduced Reed Addis of EEC who gave a presentation on the 2024 Legislative and Regulatory work of the Agency, and she noted that the second part of this item is approval of a new contract with EEC for 2025-2026.

Member Royse asked the Agency include the disposal of solar panels and the disposal of plastic in the ocean as priorities.

Staff Au noted that the legislative platform for 2025 will be discussed at the December Legislative Committee meeting and brought to the Board for approval early next year.

Vice Chair Brownrigg commented that in the Long Range Plan approved today, there is a goal to eliminate plastics from landfill, and he didn't see it explicitly called out in the presentation.

Staff Au answered that the top priority on the draft that will be reviewed by the committee next month is plastics reduction, but we can add any specific plastic to the board's discretion.

Members of the Legislative Committee commented that EEC has been a good partner, consultant the lobbyist and recommended moving forward with the contract.

Motion/Second: Royse/Lorraine

Voice Vote: 10-0-0-1

Agency	Yes	No	Abstain	Absent	Agency	Yes	No	Abstain	Absent
Belmont	X				Redwood City	X			
Burlingame	X				San Carlos	X			
East Palo Alto	X				San Mateo	X			
Foster City	X				County of San Mateo				X
Hillsborough	X				West Bay Sanitary Dist.	X			
Menlo Park	X								

9. Informational Items Only (no action required)

- A. Analysis on Increasing Rates to Fund Reserves Follow up from Previous Board Meetings
- B. Update on SB 1383 Compliance Program on behalf of RethinkWaste Member Agencies
- C. 2024-2025 Finance and Rate Setting Calendar
- D. Check Register Detail for September and October 2024
- E. 2024-2025 Meeting Planning Guide

10. Board Member Comments

Member Froomin complimented staff for the A/V quality in the office space, this was his first meeting in the new location.

11. Adjourn 3:55PM

STAFF REPORT

To: RethinkWaste Board Members
From: Joe La Mariana, Executive Director
Date: February 27, 2025 Board of Directors Meeting
Subject: Resolution to Approve the appointment of Citizen-at-Large Position to the Finance Committee Ex-Officio Board Member Al Royle

Recommendation

It is recommended that the RethinkWaste Board of Directors approve Resolution No 2025-01 attached hereto authorizing the following action:

Authorize the appointment of former RethinkWaste Board Member, Al Royle, to serve on the RethinkWaste's Finance Committee as a "Citizen at-Large" in an Ex-Officio capacity.

Summary

RethinkWaste's Finance Committee has traditionally consisted of three Board members and two Technical Advisory Committee (TAC) members. These current incumbents are:

Two Board-level Finance Committee vacancies currently exist due to the recent retirement from public service by former Board Members Al Royle (Hillsborough) and John Froomin (Foster City). Additionally, former Finance Committee member Grace Castenda (Belmont) has asked to be replaced..

In addition to filling these vacancies by the February Board Meeting, the Executive Committee, the Finance Committee and Staff recommend reconstitution of the additional, Ex Officio Board-level position specifically for former RethinkWaste Board Member and Finance Committee member Al Royle (Hillsborough) who retired from public service on December 9th, 2024. Mr. Royle brings rich and relevant experience from his previous leadership at RethinkWaste, his 40+ years with "big four" financial consultancy firm Deloitte, and his many years of service as a local elected official. RethinkWaste staff will rely on this experience and institutional knowledge to maintain important technical continuity as there will be a 60% turnover of committee members in 2025.

The Executive Director has spoken to Mr. Royle to confirm his interest in serving in this Ex Officio capacity on this committee should the Board approve this action.

Analysis

The Finance Committee provides the RethinkWaste Board and Staff with essential oversight and fiscal planning direction with its detailed review of RethinkWaste's:

- Annual Operating Budget
- 5-year Capital Improvement Plan
- Mid-year-budget and adjustments
- Independent financial and operational audits

- Agency revenue and expenses compared to tip fee rates
- Special financial projects, as assigned (i.e. CIP project components, debt service, facility planning, etc).

This committee's composition represents an excellent mix of elected oversight and senior-level Staff technical engagement. These individuals provide the Board and ratepayers with necessary guidance on the Agency's financial infrastructure.

Background

In 2021 the RethinkWaste Board of Directors approved resolution 2021-03 authorizing the creation of an Ex-Officio Board level position for former Board Member Jay Benton (Hillsborough) when he retired from public service. Mr. Benton served on the committee for an additional one year when the committee was in a similar transition in membership.

The agency and its ratepayers will directly benefit from Mr. Royse's longstanding knowledge of the agency's operations, its facilities, its contractors and major contracts, its legal/mandated and, of course, its financial priorities. This appointment will also provide the agency with critical continuity in a time with the Finance Committee will transition 60% of its members and the RethinkWaste Board of Directors will transition 40% of its members.

Fiscal Impact

There is no fiscal impact to the agency with this action.

Attachments:

Resolution 2025-01



RESOLUTION NO. 2025-01

RESOLUTION OF THE SOUTH BAYSIDE WASTE MANAGEMENT AUTHORITY (RETHINKWASTE) BOARD OF DIRECTORS

WHEREAS, RethinkWaste’s Executive Committee, Finance Committee and Staff recommend the reconstitution of a “Citizen-at-Large” Ex-Officio position specifically for former RethinkWaste Board Member and longtime Finance Committee Member Al Royse on the Agency’s Finance Committee; and

WHEREAS, Former Board member Al Royse is uniquely qualified to serve the RethinkWaste in this proposed capacity due to his distinguished 40+ year professional career with “big four” financial consultancy firm, Deloitte, Inc. and service to his community; and

WHEREAS, RethinkWaste is in the midst of an important transitional period because 1. two highly experienced and engaged Finance Committee members have just retired from public service, and a third staff level committee position is also vacant. And 2. Five newly elected officials (out of 11) have just been assigned to the RethinkWaste Board of Directors and 3. RethinkWaste is currently engaged in a period of transformative Capital Improvement Project planning for future facility and operational needs.

NOW, THEREFORE BE IT RESOLVED that the South Bayside Waste Management Authority (RethinkWaste) hereby approves the appointment of former Board Member Al Royse to the RethinkWaste Finance Committee as an Ex-Officio Board Level Member.

PASSED AND ADOPTED by the Board of Directors of the South Bayside Waste Management Authority, County of San Mateo, State of California on the 27th day of February 2025, by the following vote:

Agency	Yes	No	Abstain	Absent	Agency	Yes	No	Abstain	Absent
Belmont					Redwood City				
Burlingame					San Carlos				
East Palo Alto					San Mateo				
Foster City					County of San Mateo				
Hillsborough					West Bay Sanitary Dist				
Menlo Park									

I HEREBY CERTIFY that the foregoing Resolution No. 2025-01 was duly and regularly adopted at a regular meeting of the South Bayside Waste Management Authority on February 27, 2025

ATTEST:

Cyndi Urman, Clerk of the Board

Adam Rak, Chairperson of
South Bayside Waste Management Authority
(RethinkWaste)

STAFF REPORT

To: RethinkWaste Board Members
From: Hilary Gans, Senior Operations and Engineering Manager
Date: February 27, 2025 Board of Directors Meeting
Subject: Resolution Approving the Material Recovery Facility (MRF) Harris Baler Refurbishment at a Not to Exceed amount of \$184,475

Recommendation

It is recommended that the RethinkWaste Board of Directors approve Resolution No. 2025-02 attached hereto authorizing the following action: Resolution Approving RethinkWaste-owned Material Recovery Facility's (MRF) Harris Baler Refurbishment at a Not to Exceed amount of \$184,475

Summary

The Shoreway MRF has two industrial-scale material baling units, known as "balers" (manufactured by Harris and IPS) that process and compress all the sorted commodities into transportable bundles for shipping. The Harris baler was last refurbished in 2012 and needs major parts replacement to rebuild and re-line the inner compression compartment of the main unit. A quote for service by Olympic Baler is attached and includes 10% SBI project management cost for a total of \$184,475.

Analysis

The MRF balers are an essential part of the MRF operations. These hardworking, hydraulic powered compression mechanical units process and squeeze the sorted recyclables into one-ton standard bales for sale and shipping. The Harris baler is about 20 years old and was last refurbished approximately 12 years ago and needs major wear parts replacement and extensive labor to install them (see Attachment A). This attachment includes a work order and scope of work by Olympic Baler. It is expected that this work will extend the baler's critical useful life for another 7-10 years. Rebuilding these vital pieces of equipment is a sensible investment decision because current replacement costs for these units can easily exceed \$1M. The work is expected to take one week and will commence after all component parts are in stock. All commodity baling will be switched to the other (IPS) baler so that MRF processing will not be impacted.

Background

The baler is manufactured by Harris baler, was installed at Shoreway in 2004 and has reliably functioned for 20 years. While the baler is old, it is a reliable, proven machine that is worth the investment to extend the useful life until a new baler is purchased in the future.

Fiscal Impact

RethinkWaste maintains an MRF Equipment Replacement Reserve that anticipates major capital repairs. This Baler refurbishment project has been budgeted for \$100,000 and the balance of the expense can either be drawn from the capital reserve, but another strategy may be to use money from a budgeted project that won't be completed in 2025 or use green bond funds.

Attachments:

Resolution 2025-02

Attachment A – SBI Work Order/Olympic Baler Quote for Harris Baler Refurbishment



RESOLUTION NO. 2025-02

RESOLUTION OF THE SOUTH BAYSIDE WASTE MANAGEMENT AUTHORITY(RETHINKWASTE) BOARD OF DIRECTORS AUTHORIZING THE MRF HARRIS HRB BALER REFURBISHMENT PROJECT AT A NOT TO EXCEED AMOUNT OF \$184,475

WHEREAS, the Harris Baler is an essential piece of equipment for MRF that is owned by the RethinkWaste,

WHEREAS, the Harris HRB baler is 20 years and was last refurbished 12 years ago and is in need of significant service,

WHEREAS, the facility operator, South Bayside Industries (SBI), has provided a work order and quote from Olympic Baler for the necessary work which includes a 10% project management expense.

NOW, THEREFORE BE IT RESOLVED that the South Bayside Waste Management Authority (RethinkWaste) hereby approves a resolution authorizing the Harris HRB Baler Refurbishment Project for an NTE amount of \$184,475

PASSED AND ADOPTED by the Board of Directors of the South Bayside Waste Management Authority, County of San Mateo, State of California on the 27 day of February, 2025 by the following vote:

Agency	Yes	No	Abstain	Absent	Agency	Yes	No	Abstain	Absent
Belmont					Redwood City				
Burlingame					San Carlos				
East Palo Alto					San Mateo				
Foster City					County of San Mateo				
Hillsborough					West Bay Sanitary Dist				
Menlo Park									

I HEREBY CERTIFY that the foregoing Resolution No. 2025-02 was duly and regularly adopted at a regular meeting of the South Bayside Waste Management Authority on February 27, 2025

ATTEST:

Adam Rak, Chairperson of
South Bayside Waste Management Authority
(RethinkWaste)

Cyndi Urman, Clerk of the Board



SHOREWAY ENVIRONMENTAL CENTER
WORK ORDER REQUISITION

Date 2/5/2025

Project Number 2024-0144

Requested by: Dwight Herring

South Bayside Industries
333 Shoreway Road
San Carlos, CA 94070

RethinkWaste
610 Elm Street, Suite 202
San Carlos, CA 94070

Work Summary

Reline and repair of the HRB Baler

Area

MRF Building
 Transfer Station Building
 SBR Maintenance Shop
 Canopied Truck Shop

Scale House
 Admin Offices
 Scales
 Fencing/Security

Completed by

SBI
 Subcontractor

Project Cost

SBI Time and Materials Project
 SBI Pass Through to RethinkWaste

Estimated Hours
 Subcontractor Direct Bill to RethinkWaste

Parts Cost (Attached)
 Subcontractor Quote (Attached)

\$184,475.00

SBI Labor

Subtotal \$ 184,475.00

Markup (10%)

Total Project Expense \$ 184,475.00

Project Dates

Start

Henry Gons/Contract Manager

Finish
2/4/25
Date

RethinkWaste Approval
Name/Title

SBI Approval
Name/Title

Dwight Herring
Dwight Herring/General Manager

2/5/2025
Date



Olympic

wire and equipment, Inc.

P.O. Box 3227 ~ Newport Beach, CA. 92659

Tel (949) 646-9731 Fax (714) 436-0240

www.olympicequipment.com

10/28/24

SOUTH BAYSIDE INDUSTRIES
Robert Orique
333 Shoreway Rd.
San Carlos, CA 94070
RE: Harris Centurion SN:2825



Dear Robert,

Thank you for giving us the opportunity to quote our reline services for your Centurion Baler in San Carlos. I've provided our proposed scope of work in the outline below, it is based on a recent visit to your plant and discussions with you on mutual understanding of the baler needs. Please take a moment to read and review.

Scope of work:

- Initiate reline by disassembling baler, removing main and eject ram, door and hopper area to prepare for the reline process.
- Frame area, remove and replace all floor liners and strip liners in the Frame gather area as well as in the compression chamber area.
- Remove and replace rear side wall strips.
- Main gatherer, remove and replace the bottom, face, side strip liners and side liners.
- Main Cylinder rotate rod on gatherer back face mount.
- Main gatherer, flip knives and new hardware.
- Eject ram face & bottom also new bolts for main cylinder mount.
- Eject door, remove and replace bottom and track with hardware.
- Shear beam, remove and replace serrated knives and hardware.
- Door cylinder reseal rod end.
- Pressure wash Power Unit and Cooler.
- Re-assemble and Install all components for your Centurion Baler.
- Olympic to stand by while baler is tested for proper operation for 4 hours.

Schedule:

OW&E will provide two four men crews working 8.5 /12 hour shifts round the clock 24hrs. We will supply; welders, torches, hand tools and safety equipment as required for completing this project.

Pricing:

Approximate labor based on Straight time rates.	\$ 129,984.00
8 – 12 hours shifts – 12 hr. 24hr shifts 8 men over a weekend (Start Mon-Sat)	
Supplies	\$ 3,800.00
All Harris OEM Parts supplied	\$ 32,231.00
Travel & per Diem	\$ 12,500.00
Equipment Rental	\$ 5,960.00
Total	<u>\$ 184,475.00</u>

Validity: This Quote is good for 60 Days. Require 3-4 week advanced notice to schedule job.

Payment Terms:

40% Down Payment with order.
60% net 15 days after project is complete.

Exclusions and Exceptions:

1. Additional Equipment Rental.
2. Parts Freight Cost Not Included.
3. Hydraulic Oil.
4. Additional steel not mentioned in the scope of work.
5. Construction and processing permits.
6. Unforeseen damages outside of original scope of work.
7. *This quote is based on a clear and free from debris area.
8. *Please note this is an estimate only. If we discover additional items we will bring it to the attention of all parties involved, to discuss change order authorization before commencement of any work.

We at Olympic Wire and Equipment, Inc. would like to thank you for the opportunity to bid this work. Olympic has 28 years extensive experience working with single stream separation equipment, Baler installations, baler relines and repairs. We are competent, confident and eager to complete this project for you and South Bayside Industries.

Please call me if you have any questions reference this bid at 949 646 9731

Sincerely,

Manny Enciso



Cc:
Jim Walker

Approved by: (Please Print): _____

Signature: _____ Date: _____

Title: _____

Company: _____ PO No. _____

I UNDERSTAND MY SIGNATURE ABOVE CONSTITUTES ACCEPTANCE OF THIS QUOTATION, AND CONVERTS IT TO AN ORDER TO OLYMPIC WIRE AND EQUIPMENT, INC. I UNDERSTAND THAT PAYMENTS ARE DUE UPON THE TERMS ABOVE. MY SIGNATURE ABOVE ALSO ACKNOWLEDGES THAT IN THE EVENT OF LITIGATION TO COLLECT THE PROCEEDS DUE HEREUNDER, THE SIGNED AGREES TO PAY REASONABLE ATTORNEY FEES.

HARRIS WASTE MANAGEMENT GROUP, INC.			HRB-CENTURION		PC-331	PAGE 5
			LAYOUT BOX LINERS	L H PLAIN KNIFE		
REF. NO.	NO. REQ'D.	PART NO.	PART NAME			
1	1	D39340A	Press Box Bottom Liner (WELD ON)			
2	1	D39340B	Press Box Top Liner (WELD ON)			
3	1	D39340C	Charge Box Eject - Side Liner (WELD ON)			
4	1	D39340D	Press Box End Wall Liner (WELD ON)			
5	10	D39340Q	Wide Bed Strip Liner (WELD ON)			
6	8	D39340R	Narrow Bed Strip Liner (WELD ON)			
7	1	D39340G	Right Side Wall Liner (WELD ON)			
8	1	D39340J	Throat Liner (WELD ON)			
9	2	D39340K	Top & Bottom Exit Chute Liner (WELD ON)			
10	1	D39340L	R.H. Side Wall Liner (WELD ON)			
11	2	D39340P	Gatherer Tail Guide Strip Liner (WELD ON)			
12	8	D39195C	Door Guides			
	12	D29220A	Capscrew 1/2"-10NC x 1 1/2" 50 Deg. Fl. Hd.			
	12	D29220B	Capscrew 1/2"-10NC x 1 1/2" 50 Deg. Fl. Hd.			
	24	D29220J	Capscrew 1/2"-10NC x 3" 50 Deg. Fl. Hd.			
	24	819965	Nut, Hex, Lock 1/2"-10NC			
13	1	D39196D	Ejector Ram Guide			
	8	D29220A	Capscrew 1/2"-10NC x 4 1/2" 50 Deg. Fl. Hd.			
	8	819965	Nut, Hex, Lock 1/2"-10NC			
14	1	D39196G	Gatherer Hold Down, Rear Left			
	6	D29221M	Capscrew 1"-8NC x 5 1/2" 50 Deg. Fl. Hd.			
	6	805078	1" Washers			
	6	819966	Nut, Hex, Lock 1"-8NC			
15	1	D39196J	Gatherer Hold Down, Rear Right			
	6	D29221M	Capscrew 1"-8NC x 5 1/2" 50 Deg. Fl. Hd.			
	6	805078	1" Washers			
	6	819966	Nut, Hex, Lock 1"-8NC			
16	1	D39196L	Gatherer Hold Down, Front Right			
	8	D29221M	Capscrew 1"-8NC x 5 1/2" 50 Deg. Fl. Hd.			
	8	805078	1" Washers			
17	8	819966	Nut, Hex, Lock 1"-8NC			
	1	D39196K	Gatherer Hold Down, Front Left			
	7	D29221M	Capscrew 1"-8NC x 5 1/2" 50 Deg. Fl. Hd.			
	7	805078	1" Washers			
18	7	819966	Nut, Hex, Lock 1"-8NC			
	2	D39196E	Gatherer Hold Up			
	10	D29221M	Capscrew 1"-8NC x 5 1/2" 50 Deg. Fl. Hd.			
	10	805078	1" Washers			
	10	819966	Nut, Hex, Lock 1"-8NC			

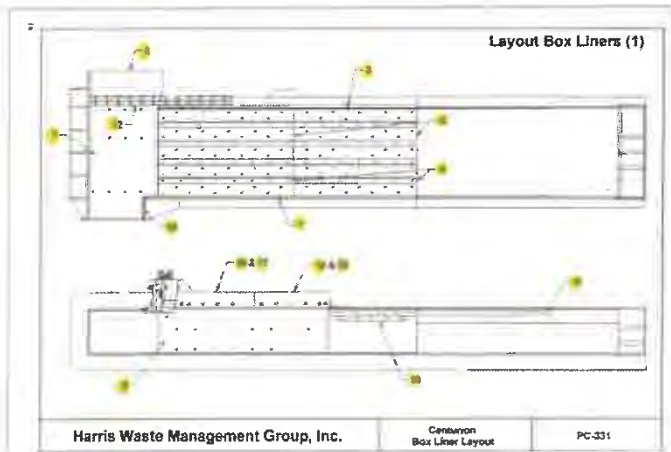

19	2	D70302D	Keeper Plate
	4	802366	Capscrew 1/2"-13nc x 1 1/4" Hex Hd.
	4	805060	1/2" Lockwasher
20	1	D70302C	Pin
21	1	D3915DA	Boiling Ring
22	6	818055	Capscrew 1 1/4"-7nc x 5" Lg. Soc. Hd.
	6	818216	1 1/4" Lockwasher
23	1	202967000	Split Bolting Ring

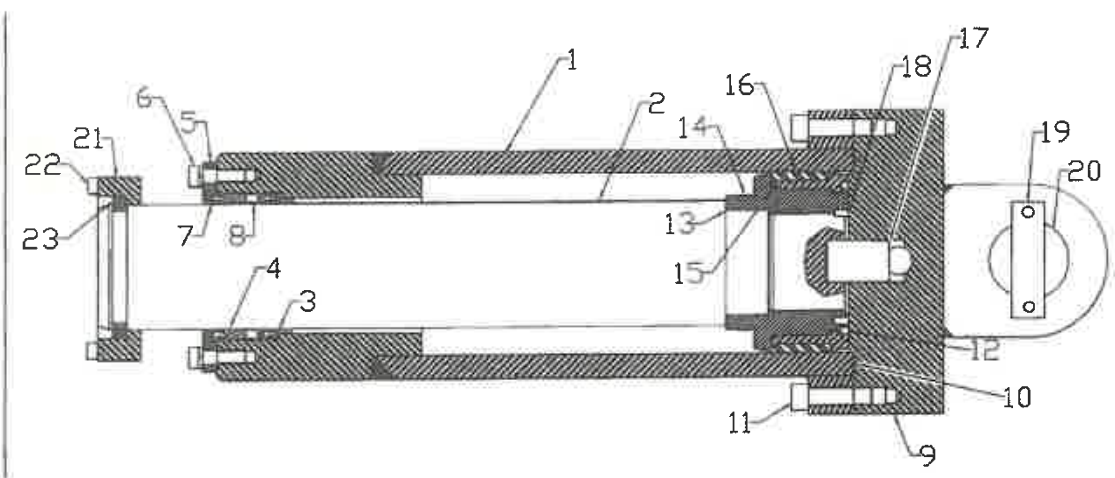

HARRIS WASTE MANAGEMENT GROUP, INC.	HRB-CENTURION GATHERER RAM LINERS	PC-331	PAGE 7
-------------------------------------	--------------------------------------	--------	--------

REF. NO.	NO. REQ'D.	PART NO.	PART NAME
1	1	D42313A	Top Face Liner (WELD ON)
2	1	D42313C	Bottom Face Liner (WELD ON)
3	4	D39167B	Side Liners
	2	D29220J	Capscrew 3/4"-10NC x 3" 50 Deg. Fl. Hd.
	22	D29220P	Capscrew 3/4"-10NC x 4" 50 Deg. Fl. Hd.
	22	819965	Nut 3/4"-10NC Hex Lock
4	5	D39167C	Bottom Strip Liners (WELD ON)
5	2	D27988A	Knife 2 X5 X 28.43
6	8	D30345A	Knife Washers
7	8	D20754G	Capscrew 1 1/4"-7NC x 4" 50 Deg. Fl. Hd.
8	4	809654	Jack Bolts 1 1/4"-7NC x 4" Hex Hd.
	4	804769	Jam Nut 1 1/4"
9	1	D39149A	Gatherer Ram

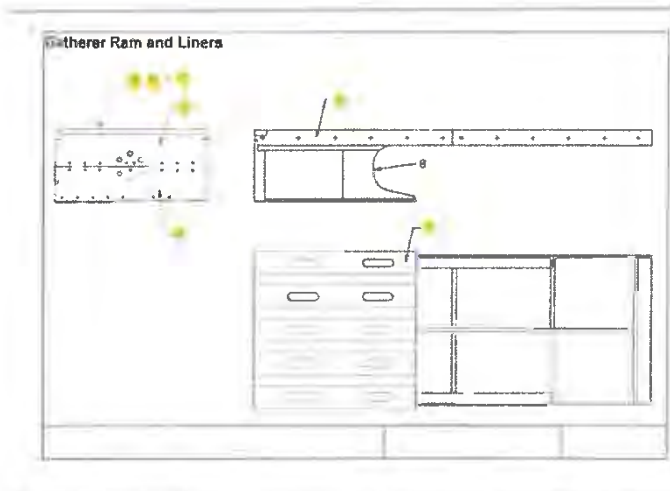

REF. NO.	NO. REQ'D.	PART NO.	PART NAME
1	1	D39005A	Cylinder Tube 7" Dia.
2	1	D39012A	Piston Rod 3 1/2" Dia.
3	1	D39013B	Inner Bushing
4	1	D29590A	Outer Bushing
5	1	D29591A	Packing Retainer
6	6	809543	Cap screw 5/8"-11NC X 1 1/4" Lg. Soc. Hd.
	6	818209	5/8" Lockwasher
7	1	855041	Rod Seal
8	1	855040	Rod Wiper
9	1	805404	Rod "O" Ring (313.13)
10	1	D02694A	Cushion Piston 1 1/2"
11	1	D20527F	Rod Dowel Pin 1/2" x 3/4"
12	1	D39008A	Rear Head
13	1	834117	"O" Ring (775.13)
14	11	818015	Cap screw 7/8"-9NC X 3 1/2" Lg. Soc. Hd.
15	1	D39010A	Piston Hub
16	1	805407	"O" Ring (550.13)
17	1	D20527A	Piston Head Dowel 1/4" x 3/8"
18	1	D39011A	Packing Ring
19	1	D39013A	Rod End
20	2	203706000	2" x 7" Pin
	4	108765004	Cotter Pin

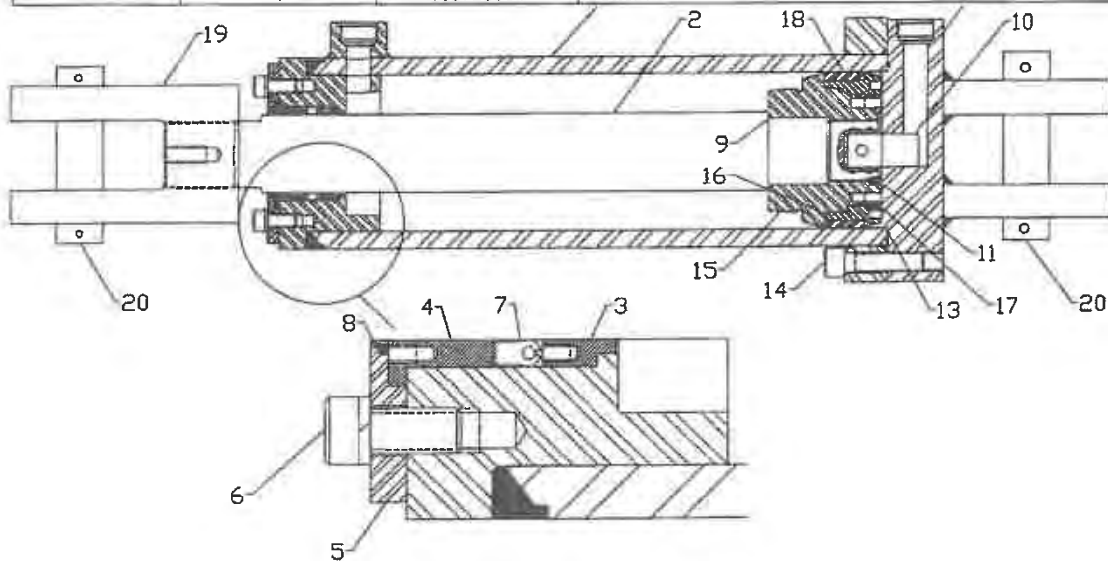

REF. NO.	NO. REQ'D.	PART NO.	PART NAME
1	2	D39170B	Guide Liners (WELD ON)
2	2	D39170C	Side Liners (WELD ON)
3	1	D39170F	Front Bottom Liners (WELD ON)
4	2	D39170G	Bottom Side Liners (WELD ON)
5	1	D39169A	Ejector Ram

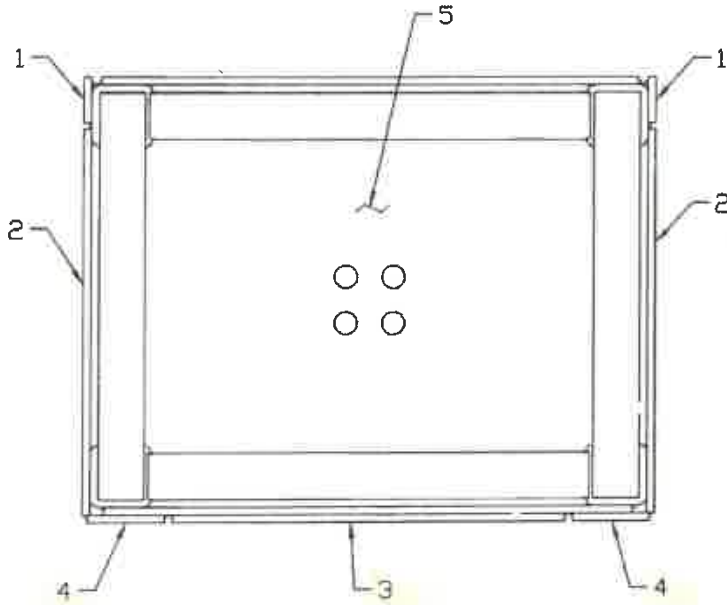

REF. NO.	NO. REQ'D.	PART NO.	PART NAME
1	2	D39155A	Front Liners (WELD ON)
2	2	204121000	Side Liners (WELD ON)
3	2	204122000	Top & Bottom Liners (WELD ON)
4	1	D39190A	Combo Door
5	2	204123000	Door Guide
6	22	809513	Capscrew 3/4"-10NC x 3" Soc. Hd.
	22	116595001	Washers 3/4"

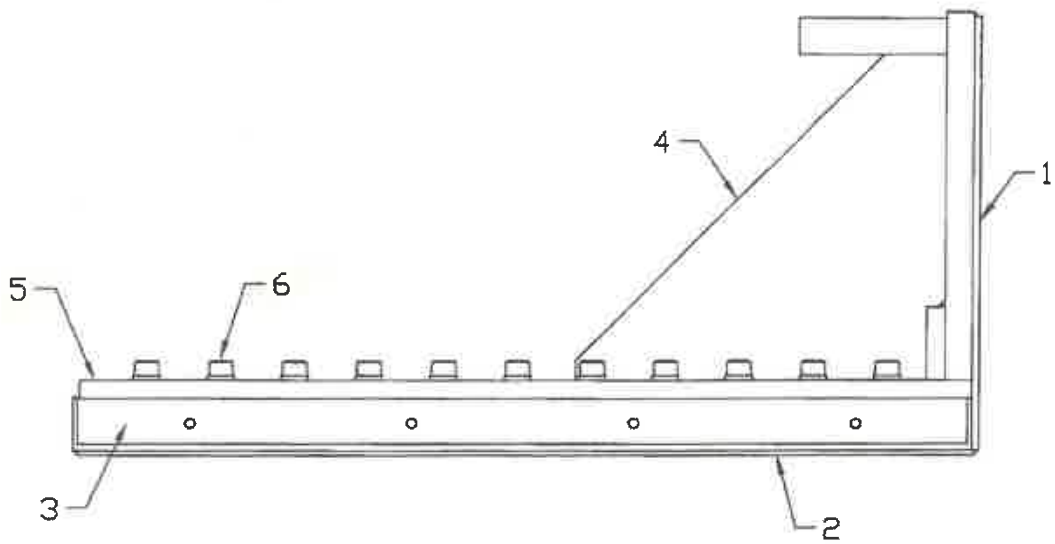

PLEASE NOTE: THE LEAD TIME ON PARTS FROM HARRIS CURRENTLY IS 4 - 5 WEEKS
ANY REQUEST FOR QUICKER LEAD TIMES FROM HARRIS WILL ADD A 20% MARK UP
TO PARTS DIRRECTLY FROM HARRIS.

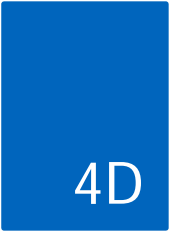

STAFF REPORT

To: RethinkWaste Board Members
From: John Mangini, Senior Finance Manager
Date: February 27, 2025 Board of Directors Meeting
Subject: Approval of Quarterly Investment Report for the Quarter Ended December 31, 2024

Recommendation

It is recommended that the RethinkWaste Board review and accept the Quarterly Investment Report.

Analysis

The primary objective of the Investment Policy for RethinkWaste is safety of principal, while meeting the cash flow needs of the Authority, through prudent investment of unexpended cash. As of December 31, 2024, the investment portfolio was compliant with the Investment Policy. The portfolio contains sufficient liquidity to meet the next six months of expected expenditures by the Authority as well as by other third parties.

Fiscal Impact

The attached Investment Portfolio Summary indicates that as of December 31, 2024, funds in the amount of \$28,615,562 were invested, producing a weighted average yield of 4.2%.

Below is a summary of the changes from the last quarter.

	Qtr Ended 9/30/2024	Qtr Ended 12/31/2024	Increase (Decrease)
Total Portfolio	\$31,678,984	\$28,615,562	(\$3,063,421)
Weighted Average Return	4.5%	4.2%	-0.3%
Interest/Dividends Earnings	\$403,732	\$322,454	(\$81,278)

The total quarter-end portfolio balance decreased by \$3,063,421 when compared with the previous quarter. The decrease is mainly due to transfers out of the LAIF account to cover expenditure payments, which included capital project payments for the underground storage tank replacement. Total interest and dividend earnings were slightly lower than in the previous quarter due to the decrease in the total portfolio.

A table comparison of the portfolio components is provided below:

	9/30/2024	% of	12/31/2024	% of	Change over
	Balance	Total	Balance	Total	Prior
					Quarter
SM County Pool	\$10,149,147	32.0%	\$10,247,988	35.8%	\$98,841
LAIF	7,760,988	24.5%	4,883,921	17.1%	(2,877,067)
Bond Accounts	13,768,849	43.5%	13,483,653	47.1%	(285,196)
Total Portfolio	\$31,678,984	100.0%	\$28,615,562	100.0%	(\$3,063,421)

Note: There may be minor differences in totals as individual amounts are rounded

Due to arbitrage restrictions, bond investments are not included in our Local Agency Investment Fund (LAIF) rate or investment pool comparison. As of December 31, 2024, the bond project accounts of \$13.5 million were invested with the trustee in cash and short-term investments.

As of December 31, 2024, investment in the County Investment Pool totaled 35.8% of RethinkWaste's funds available for investment pools (see Attachment 1), while the investment in LAIF totaled 17.1%. These percentages are within the range specified by the RethinkWaste Board.

The weighted average yield of the portfolio in the quarter excluding the bond proceeds was 4.2%. LAIF is used as a benchmark and the average LAIF yield for the quarter ending December 31, 2024, was 4.43%, lower than the 4.58% in the prior quarter. The San Mateo County Pool average yield for the quarter was 3.84%, lower than the 3.87% in the prior quarter.

Attachments

- A – Summary of All Investments for Quarter Ending December 31, 2024
- B – Investment Portfolio 12/31/2024 Chart
- C – Historical Summary of Investment Portfolio

SOUTH BAYSIDE WASTE MANAGEMENT AUTHORITY
SUMMARY OF ALL INVESTMENTS
 For Quarter Ending December 31, 2024

Category	Rate of Return	Historical Cost	% of Portfolio	Market Value*	Interest/Dividend Earned
Liquid Investments:					
San Mateo County Investment Pool (COPOOL)	3.84%	\$ 10,247,988	67.7%	\$ 10,240,712	\$ 96,643
Local Agency Investment Fund (LAIF)	4.43%	4,883,921	32.3%	\$ 4,882,075	60,104
	Weighted Average				
Total - Investments	4.03%	15,131,909	100.0%	15,122,787	156,747
	Rate of Return				
Bond Accounts - Cash with Fiscal Agents					
BNY - 2009A Reserve Fund	0.00%	-		-	-
BNY - 2009A Payment Fund	0.00%	-		-	-
BNY - 2019AB Payment Fund 762666	4.35%	9,852		9,852	810
BNY - 2019AB Refunding Costs Fund 762667	0.00%	1		1	-
BNY - 2019AB Refunding Project Fund 762668	4.35%	13,473,800		13,473,800	164,897
Total - Bond Accounts	4.35%	13,483,653		13,483,653	165,707
	Weighted Average				
GRAND TOTAL OF PORTFOLIO	4.18%	\$ 28,615,562		\$ 28,606,440	\$ 322,454
Total Interest/Dividend Earned This Quarter					322,454
Total Interest/Dividend Earned Fiscal Year-to-Date					1,511,960

Note: Rethinkwaste Board approved the following investment mix at its January 26, 2023 meeting:
 LAIF - up to 80%
 COPOOL - up to 80%

*Difference in value between Historical Cost and Market Value may be due to timing of purchase. Investments in the investment pools may have been purchased when interest rates were lower or higher than the end date of this report. As interest rates increase or decrease, the value of the investment pools will decrease or increase accordingly. However, interest rate fluctuations do not have any impact to SBWMA's balance in the investment pools (other than interest earnings). The market values are presented as a reference only and are used for accounting purposes.

**RethinkWaste
Investment Portfolio
12/31/2024**

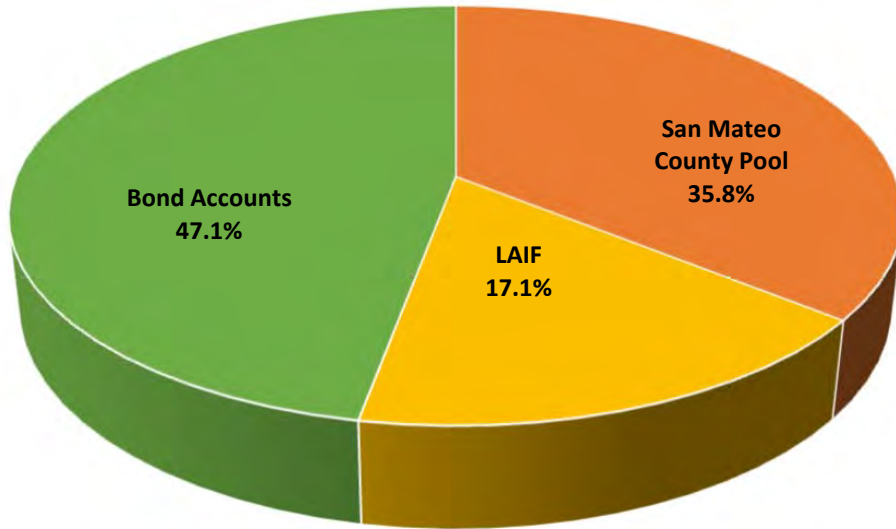

■ San Mateo County Pool ■ LAIF ■ Bond Accounts

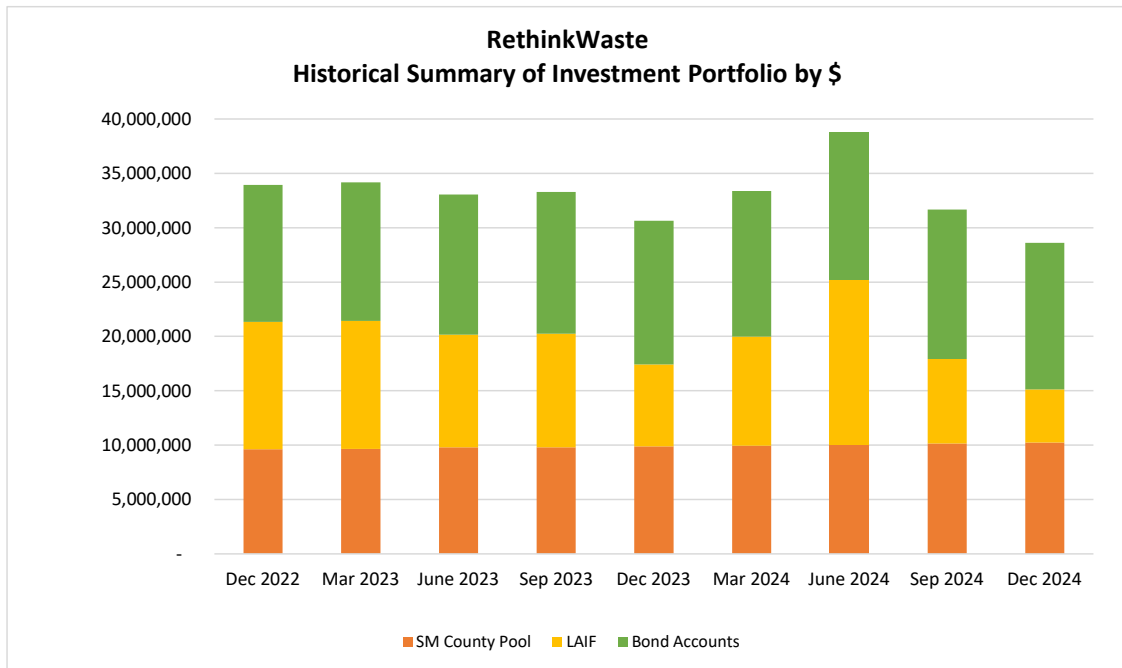

South Bayside Waste Management Authority Portfolio

	Dec 2022	Mar 2023	June 2023	Sep 2023	Dec 2023	Mar 2024	June 2024	Sep 2024	Dec 2024
SM County Pool	9,616,995	9,659,807	9,792,546	9,792,546	9,872,137	9,957,601	10,050,709	10,149,147	10,247,988
LAIF	11,712,786	11,777,465	10,356,840	10,442,419	7,536,580	10,017,014	15,122,986	7,760,988	4,883,921
Bond Accounts	12,613,225	12,744,217	12,897,168	13,065,846	13,236,637	13,410,942	13,586,892	13,768,849	13,483,653
Grand Total	\$ 33,943,006	\$ 34,181,489	\$ 33,046,554	\$ 33,300,811	\$ 30,645,354	\$ 33,385,557	\$ 38,760,587	\$ 31,678,984	\$ 28,615,562

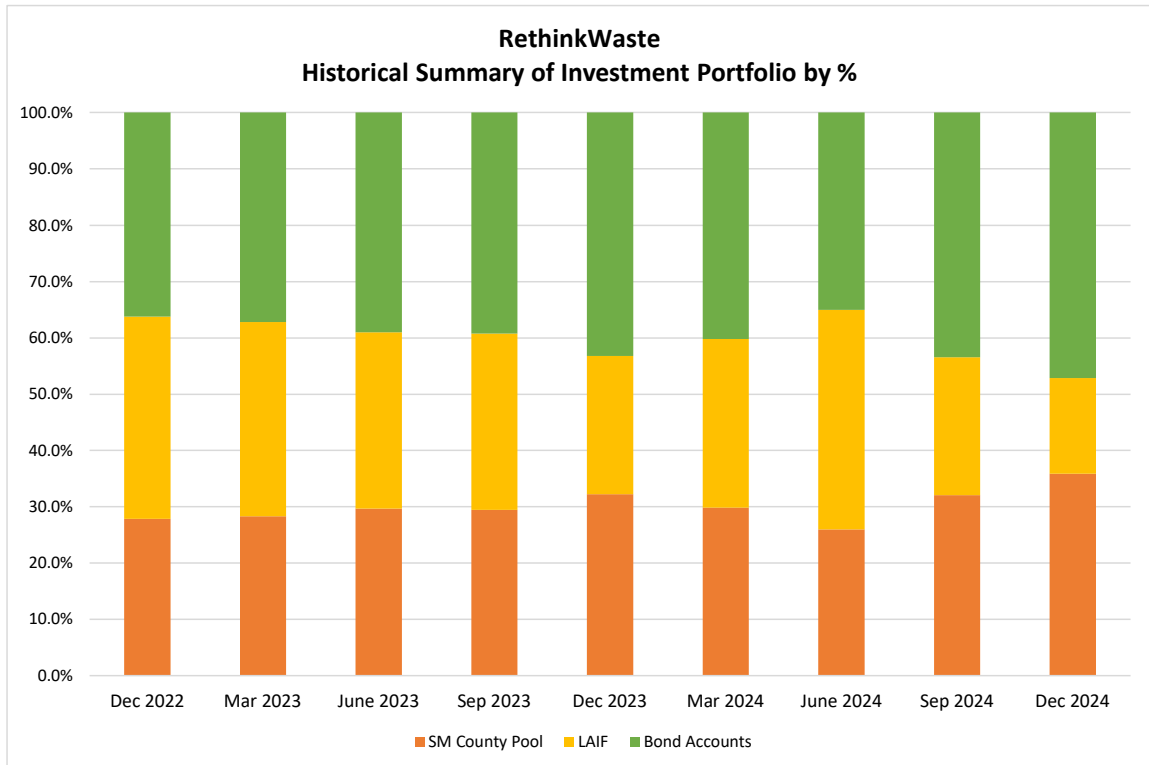

	Dec 2022	Mar 2023	June 2023	Sep 2023	Dec 2023	Mar 2024	June 2024	Sep 2024	Dec 2024
SM County Pool	27.8%	28.3%	29.6%	29.4%	32.2%	29.8%	25.9%	32.0%	35.8%
LAIF	36.0%	34.5%	31.3%	31.4%	24.6%	30.0%	39.0%	24.5%	17.1%
Bond Accounts	36.2%	37.2%	39.0%	39.2%	43.2%	40.2%	35.1%	43.5%	47.1%
Grand Total	100.0%	100.0%	100.0%	100.0%	100.0%	100.0%	100.0%	100.0%	100.0%



ADMINISTRATION AND FINANCE

STAFF REPORT

To: RethinkWaste Board Members
From: Cyndi Urman, Clerk of the Board
Date: February 27, 2025 Board of Directors Meeting
Subject: Election of RethinkWaste Chair and Vice Chair for 2025

Recommendation

The Board is required to annually elect a Board Chair and Vice Chair per Article 8, Governance, of the JPA Agreement, Sections 8.5 and 8.6 which provide:

8.5 Chair. The Board shall annually select a Chair, by a vote taken in accordance with Section 10.8 of this Agreement, who shall serve without compensation at the pleasure of the Board. The duties of the Chair include, but are not limited to the following:

- a. Conduct Board meetings.
- b. Review and set meeting agendas with the Executive Director.
- c. Sign any and all RethinkWaste official documents.

8.6 Vice Chair. The Board shall annually select a Vice Chair, by a vote taken in accordance with Section 10.9 of this Agreement, who serves without compensation at the pleasure of the Board. The Vice Chair shall act in the absence of the Chair, with full powers of the Chair.

This selection has traditionally occurred at the Board's January meeting. Staff recommends that the Board now select the Chair and Vice Chair for 2025.

In addition to the duties enumerated in Section 8.5 & 8.6, as a matter of practice, the Board Chair and Vice Chair along with the Executive Director, General Counsel and Board Clerk have traditionally met on a monthly basis as the "Executive Committee" to conduct Board meeting agenda planning and discuss major items of note related to JPA operations. The Executive Director also updates the Executive Committee on a regular basis on any major issues that may come up in the course of day-to-day operations.

Background

Staff recommends the following process for the Board to follow in electing a Chair and Vice Chair for calendar year 2025:

1. Current Chair calls for nominations for the position of Chair (nominations do not require a second).
2. Motion is adopted to close nominations.

3. Board votes on nominations in the order in which the nominations were made until a Chair is elected.
4. Sections 8.5 and 10.8 of the JPA Agreement require the successful vote to be by 2/3 of the Directors present.
5. The new Chair takes the gavel and assumes the office and calls for nominations for Vice Chair and the same procedure is followed for electing the Vice Chair.

Fiscal Impact

None.

Attachments:

None.

STAFF REPORT

To: RethinkWaste Board Members
From: Joe La Mariana Executive Director
Cyndi Urman, Clerk of the Board
Date: February 27, 2025 Board of Directors Meeting
Subject: Resolution Approving 2025 Vacant RethinkWaste Committee Appointments

Recommendation

It is recommended that the RethinkWaste Board of Directors approve Resolution No 2025-03 appointing Board Members and TAC Members to serve on the RethinkWaste committees. It is also recommended that at today's meeting the Board select from its Members to fill each of the vacant seats in the committees listed below, as well as appoint a TAC member to fill the vacant TAC member position on the Public Education/Outreach Committee, and a Finance Director to fill the vacant member agency Finance Director Vacancy on the Finance Committee. It is further recommended that every two years when the agency's committees are constituted, a Chair is selected by a majority of the committee members. Committee Chairs will lead Committee meetings and collaborate with Staff to develop agendas and discussion items, and when appropriate, report back to the Board on key agency initiatives.

Summary

Staff requests the appointment of Two Board Members and one Finance Director to the Finance Committee, two Board Members to the Legislative Committee, one Board Member and one Technical Advisory Committee (TAC) member to the Public Education and Outreach Committee, and one Board Members to the Zero Waste Committee to fill Committee vacancies. As with the committee appointment process in the past, this resolution will formally appoint Board Members and TAC Member to committee positions and supersedes all previous resolutions.

Staff requests that the Board appointments be decided at today's meeting.

Finance Committee (Standing Committee of Board and Member Agency Sr. Finance Staff)

- Michael Brownrigg – Board Member, Burlingame City Council
- Fran Dehn - Board Member, West Bay Sanitary District*
- Adam Loraine – Board Member, San Mateo City Council*
- _____ – Finance Director
- Rebecca Mendenhall – San Carlos Finance Director
- Staff: John Mangini (Lead); Cyndi Urman; Joe La Mariana

Legislative Committee (Standing Committee of Board Members)

- Adam Rak – Board Member, San Carlos City Council
- Adam Loraine – Board Member, San Mateo City Council
- Jeff Schmidt – Board Member, Menlo Park City Council*
- _____ – Board Member

- Staff: Julia Au (Lead); Joe La Mariana

Public Education/Outreach Committee (Adhoc Committee of Board and TAC Members)

- Carlos Romero – Board Member, East Palo Alto City Council
- _____ – Board Member
- _____ – Board Member
- Gordon Tong – TAC Member, County of San Mateo, Sustainability Department
- _____ – TAC Member
- Siliva Pa'uli – TAC Alternate Member, San Mateo, Solid Waste Recycling Programs Coordinator
- Vicki Sherman – Environmental Initiatives Coordinator, Redwood City Public Works
- Alexandra Rinear – Waste Zero Manager, Recology SMC
- Staff: Emi Hashizume (Co-Lead); Joanna Rosales-Jose (Co-Lead); Julia Au; Joe La Mariana

Zero Waste Committee (Adhoc Committee of Board Members)

- Tom McCune – Board Member, Belmont City Council
- Michael Brownrigg – Board Member, Burlingame City Council
- **Fran Dehn, Board Member West Bay Sanitary District***
- Adam Rak – Board Member, San Carlos City Council
- Adam Loraine – Board Member, San Mateo City Council
- Staff: Hilary Gans (Lead); Matt Southworth; John Mangini; Joanne Nghiem; Joe La Mariana

*Staff recommended new committee member

_____ = Committee Vacancy to be filled at the February 2025 Board Meeting

Background

In 2021, RethinkWaste staff looked at the historical process for appointing committee members and determined that there was no formal process for appointing committee members which resulted in different approaches to addressing this issue. Legal Counsel recommended a resolution be approved to formalize the process of appointing committee members going forward. New committee members are now appointed as vacancies need to be filled and appointment is made by Board resolution.

Fiscal Impact

There is no fiscal impact associated with appointing RethinkWaste committee members.

Attachments:

Resolution 2025-03



RESOLUTION NO. 2025-03

RESOLUTION OF THE SOUTH BAYSIDE WASTE MANAGEMENT AUTHORITY (RETHINKWASTE) BOARD OF DIRECTORS APPOINTING RETHINKWASTE COMMITTEE MEMBERS

WHEREAS, In January 2025 there were several vacancies on RethinkWaste standing and Adhoc Committees' and

WHEREAS, As established in 2021 a formal system to appoint Board Members as members of the standing and adhoc RethinkWaste committees was put into place.

NOW, THEREFORE BE IT RESOLVED that the South Bayside Waste Management Authority hereby approves the appointment of these Board Members to the following committees:

Finance Committee (Standing Committee of Board and Member Agency Sr. Finance Staff)

- Michael Brownrigg – Board Member, Burlingame City Council
- Fran Dehn - Board Member, West Bay Sanitary District*
- Adam Loraine – Board Member, San Mateo City Council*
- _____ – Finance Director
- Rebecca Mendenhall – San Carlos Finance Director
- Staff: John Mangini (Lead); Cyndi Urman; Joe La Mariana

Legislative Committee (Standing Committee of Board Members)

- Adam Rak – Board Member, San Carlos City Council
- Adam Loraine – Board Member, San Mateo City Council
- Jeff Schmidt – Board Member, Menlo Park City Council*
- _____ – Board Member
- Staff: Julia Au (Lead); Joe La Mariana

Public Education/Outreach Committee (Adhoc Committee of Board and TAC Members)

- Carlos Romero – Board Member, East Palo Alto City Council
- _____ – Board Member
- _____ – Board Member
- Gordon Tong – TAC Member, County of San Mateo, Sustainability Department
- _____ – TAC Member
- Siliva Pa'uli – TAC Alternate Member, San Mateo, Solid Waste Recycling Programs Coordinator
- Vicki Sherman – Environmental Initiatives Coordinator, Redwood City Public Works
- Alexandra Rinear – Waste Zero Manager, Recology SMC

- Staff: Emi Hashizume (Co-Lead); Joanna Rosales-Jose (Co-Lead); Julia Au; Joe La Mariana

Zero Waste Committee (Adhoc Committee of Board Members)

- Tom McCune – Board Member, Belmont City Council
- Michael Brownrigg – Board Member, Burlingame City Council
- **Fran Dehn, Board Member West Bay Sanitary District***
- Adam Rak – Board Member, San Carlos City Council
- Adam Loraine – Board Member, San Mateo City Council
- Staff: Hilary Gans (Lead); Joanne Nghiem; John Mangini; Joe La Mariana

PASSED AND ADOPTED by the Board of Directors of the South Bayside Waste Management Authority, County of San Mateo, State of California on the 27th day of February, 2025, by the following vote:

Agency	Yes	No	Abstain	Absent	Agency	Yes	No	Abstain	Absent
Belmont					Redwood City				
Burlingame					San Carlos				
East Palo Alto					San Mateo				
Foster City					County of San Mateo				
Hillsborough					West Bay Sanitary Dist				
Menlo Park									

I HEREBY CERTIFY that the foregoing Resolution No. 2025-03 was duly and regularly adopted at a regular meeting of the South Bayside Waste Management Authority on February 27, 2025.

ATTEST:

Adam Rak, Chairperson of South Bayside Waste Management Authority (RethinkWaste)

Cyndi Urman, Clerk of the Board



SHOREWAY OPERATIONS AND CONTRACT MANAGEMENT

Agenda Item 7

STAFF REPORT

To: RethinkWaste Board Members
From: Hilary Gans, Senior Operations and Engineering Manager
Date: February 27, 2025 Board of Directors Meeting
Subject: Resolution Authorizing the Payment of \$357,191.18 to SBI for the Replacement of the Material Recovery Facility (MRF) Screen Disks

Recommendation

It is recommended that the RethinkWaste Board of Directors approve Resolution No. 2024-04 attached hereto authorizing the following action: Resolution Approving the payment of \$357,191.18 to SBI for the Replacement of MRF Screen Disks.

Summary

The Shoreway MRF sort system uses screens to sort recyclable materials by size, there are 9 screens with 50 to 100 rubber disks mounted on the screens. These disks wear from friction as they sort materials (the average life of a disk is 24 months). When SBI started their operation contract, there was substantial wear on the MRF Disks because SBR did not replace the screen disks as part of the normal plant preventive maintenance. This wear, combined with wear from SBI's operation of the MRF sort system have accumulated into a need for a mass replacement of the rubber disks. The portion of wear occurred prior to SBI arriving at the MRF (66%) is proposed to be paid by RethinkWaste while the share of wear from SBI's operations (33%) is proposed to be paid by SBI.

Analysis

The MRF screen disks are a fundamental component of the MRF sorting system in that they form a matrix that sifts the recyclables by size and type. These rubber disks have a wear life of roughly 24 months and need to be replaced on a consistent basis as part of a preventative maintenance program. In this case, SBR failed to maintain the screens or replace the rubber disks during the last year of their contract. Hence, when SBI took over operations in July of 2024, many of the disks were worn beyond their functional life (See **Figure 1** Below, Screen Disks)

SBI approached RethinkWaste staff with the request to pay for the portion of the disk replacement wear that happened prior to the company's arrival onsite (note that prior to the operator transition the RethinkWaste hired a consultant Sloan Vasquez Assoc. to perform an equipment condition assessment of the MRF sort system and this report corroborates the wear of the screen disks claimed by SBI. It is also the case that SBI has operated the MRF for more than 8 months since they assessed the disk wear and requested help from the RethinkWaste to pay for the replacement. Staff and SBI analyzed the proportion of disk wear attributable to SBR and SBI, a negotiated a split of the total cost of replacement where RethinkWaste pays 66% of the cost of replacement and SBI pays 33%.

A quote for parts and labor to change the screen disks was obtained and the total cost \$464,801 (= \$355,059 Parts + \$109,742 Labor) (see **Attachment B, SBI Work Order**). As mentioned above, Staff proposes that this amount be split between the RethinkWaste and SBI in the amounts of \$357,191.18 and \$155,077 respectively.

Staff has obtained an understanding with SBI that this is a one-time cost sharing because of the pre-existing conditions of the sort equipment and that from hereafter, SBI will be responsible for the full cost of screen disk replacement as part of the company's preventative maintenance program and as spelled out in the Operations Agreement.

Figure 1 Screen Deck and Individual Disks

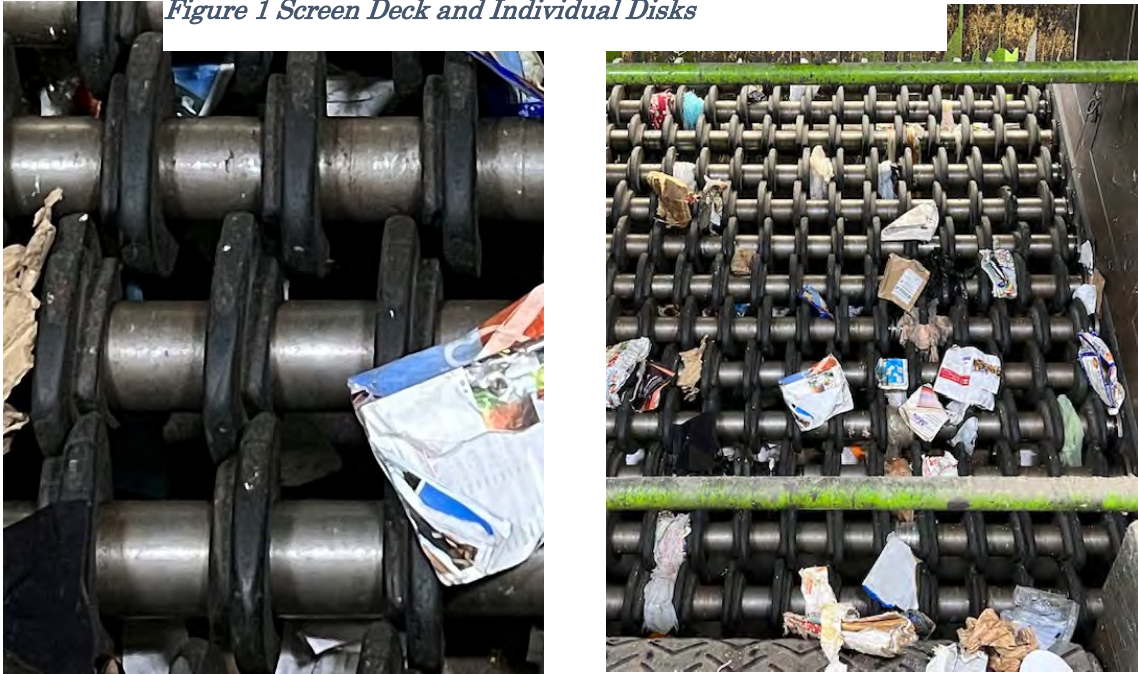

Background

The MRF sort system was originally installed in 2009 and has been maintained by SBR during their 13 years of facility operations. SBR replaced the screen disks on a regular basis but due to labor shortages and cost cutting measures the company's typical preventative maintenance and wear part replacement suffered. As a result, there was an accumulation of differed maintenance projects when SBI took over the operations of the Shoreway Facility. Staff has worked with the SBI to "catch up" on differed maintenance projects inherited by SBI at the start of the new operations contract.

Fiscal Impact

RethinkWaste proposes to apply the Green Bond funds to pay for this project. The original amount of Green Bond funds was \$12M. After interest income and charges to this account, the current balance is \$13.5M. After this payment is made it is anticipated that the Green Bond fund total will be \$13.2M

Attachments:

Resolution 2024-04

Attachment B – SBI Work Order for the Replacement of MRF Screen Disks



RESOLUTION NO. 2024-04

RESOLUTION OF THE SOUTH BAYSIDE WASTE MANAGEMENT AUTHORITY (RETHINKWASTE) BOARD OF DIRECTORS AUTHORIZING THE PAYMENT OF \$357,191.18 TO SBI FOR THE REPLACEMENT OF MRF SCREEN DISKS

WHEREAS, the screens are an essential element of the MRF sorting equipment owned by RethinkWaste; and

WHEREAS, a large number of the screen disks need to be replaced due to wear that occurred prior to SBI taking over the operations of the MRF and therefore are not the company's responsibility; and

WHEREAS, RethinkWaste and SBI have agreed to share the cost of disk replacement to reflect each entities proportional responsibility and this split has been applied to a quote for replacing the necessary parts.

NOW, THEREFORE BE IT RESOLVED that the South Bayside Waste Management Authority hereby approves a Resolution Authorizing payment of \$357,191.18 to SBI for the replacement of screen disks.

PASSED AND ADOPTED by the Board of Directors of the South Bayside Waste Management Authority, County of San Mateo, State of California on the 27th day of February, 2025 by the following vote:

Agency	Yes	No	Abstain	Absent	Agency	Yes	No	Abstain	Absent
Belmont					Redwood City				
Burlingame					San Carlos				
East Palo Alto					San Mateo				
Foster City					County of San Mateo				
Hillsborough					West Bay Sanitary Dist				
Menlo Park									

I HEREBY CERTIFY that the foregoing Resolution No. 2024-04 was duly and regularly adopted at a regular meeting of the South Bayside Waste Management Authority on February 27, 2025

ATTEST:

Adam Rak, Chairperson of
South Bayside Waste Management Authority
(RethinkWaste)

Cyndi Urman, Clerk of the Board



SHOREWAY ENVIRONMENTAL CENTER WORK ORDER REQUISITION

Date 3/1/2024

Project Number **2024-0021**

Requested by: Dwight Herring

South Bayside Industries
333 Shoreway Road
San Carlos, CA 94070

RethinkWaste
610 Elm Street, Suite 202
San Carlos, CA 94070

Work Summary Purchase & Installation of Discs for Screens 96, 110, 126, 128, and OCC screens to include shafts, parts and materials.

Area MRF Building
 Transfer Station Building
 SBR Maintenance Shop
 Canopied Truck Shop

Scale House
 Admin Offices
 Scales
 Fencing/Security

Completed by SBI
 Subcontractor

Project Cost SBI Time and Materials Project
 SBI Pass Through to RethinkWaste

Estimated Hours
 Subcontractor Direct Bill to RethinkWaste

<input checked="" type="checkbox"/> Parts Cost (Attached)	\$355,899.00
<input checked="" type="checkbox"/> Subcontractor Quote (Attached)	\$109,740.00
<input checked="" type="checkbox"/> SBI Portion 1/3	(\$155,077.79)
Markup (10%)	\$46,569.91
Total Project Expense	\$357,191.18

Project Dates Start

Finish

RethinkWaste Approval Name/Title Hilary Gans/Contracts Manager

Date

SBI Approval *Dwight Herring*
Name/Title Dwight Herring/General Manager

2/11/2025
Date



Priority Service Proposal

Date: 2/5/2025
 Expiration Date: 3/7/2025

Customer: SOUTH BAYSIDE INDUSTRIES
 333 SHOREWAY ROAD
 SAN CARLOS, CA 94070

Requestor:
 Email:

Proposal No. PSQ1825338
 Customer No. 18580
 Prepared By: GaryL
 Email: glee@bhsequip.com

Ship To: SOUTH BAYSIDE INDUSTRIES
 333 SHOREWAY ROAD
 SAN CARLOS, CA 94070

Contact No.

Line No.	Item #	Description	Equipment #	Qty	U/M	Unit Price	Ext. Price
1	A1-850-RF-A-SVC	TRIDISC, A1-850-RF-A, ASSEMBLY W/ WASHER	51	68	EA	\$24.66	\$1,676.88
2	000-0907_A	BEARING: DODGE, P2B-S2-115R,1 15/16"	50A	14	EA	\$361.49	\$5,060.86
3	000-1268-0010_A	SPROCKET, SP TP DS100A15H X Q2 x 115, TD	50A	5	EA	\$143.83	\$719.15
4	000-1267-0005_A	CHAIN: ROLLER 29RC100 W/O&C LINK	50A	5	EA	\$30.56	\$152.80
5	A1-815-RS-A	2" END DISC RUBBER	128	5	EA	\$42.14	\$210.70
6	A1-816-RS-A	1" END DISC RUBBER	128	5	EA	\$20.00	\$100.00
7	810-CS-B	POLISHER DISC - INTERLOCKING SPACER	128	60	EA	\$4.30	\$258.00
8	A1-800-RF-A-SVC	TRIDISC, A1-800-RF, ASSEMBLY W/ WASHER I	128A	222	EA	\$27.40	\$6,082.80
9	A1-800-RF-A-SVC	TRIDISC, A1-800-RF, ASSEMBLY W/ WASHER I	128B	43	EA	\$27.40	\$1,178.20
10	A1-850-RF-A-SVC	TRIDISC, A1-850-RF-A, ASSEMBLY W/ WASHER	110B	181	EA	\$24.66	\$4,463.46
11	000-0950_A	1/4"-20 X 70MM L, BINDING SCREWS FOR WOO	46	1380	EA	\$2.00	\$2,760.00
12	000-0951_A	1/4"-20 X 17MM L, BRONZE-PLTD STL CAP NU	46	1380	EA	\$1.50	\$2,070.00
13	A1-762-RB	RUBBER TRI-DISC: BHS #A1-762-RB	44A	100	EA	\$115.00	\$11,500.00
14	Shaft	OCC98 IMPACT SHAFT. BUILT AS ORIGINAL. READY TO INSTALL. NEED EQUIPMENT NUMBER.		2	EA	\$6,404.43	\$12,808.86
15	Shaft	OCC98 STANDARD SHAFT. BUILT AS ORIGINAL. READY TO INSTALL. NEED EQUIPMENT NUMBER.		5	EA	\$5,604.23	\$28,021.15



Priority Service Proposal

Date: 2/5/2025
 Expiration Date: 3/7/2025

Customer: SOUTH BAYSIDE INDUSTRIES
 333 SHOREWAY ROAD
 SAN CARLOS, CA 94070

Requestor:
 Email:

Proposal No. PSQ1825338
 Customer No. 18580
 Prepared By: GaryL
 Email: glee@bhsequip.com

Ship To: SOUTH BAYSIDE INDUSTRIES
 333 SHOREWAY ROAD
 SAN CARLOS, CA 94070

Contact No.

Line No.	Item #	Description	Equipment #	Qty	U/M	Unit Price	Ext. Price
16	000-0950_A	1/4"-20 X 70MM L, BINDING SCREWS FOR WOO		1175	EA	\$2.00	\$2,350.00
17	000-0951_A	1/4"-20 X 17MM L, BRONZE-PLTD STL CAP NU		1175	EA	\$1.50	\$1,762.50
18	A1-762-RB	RUBBER TRI-DISC: BHS #A1-762-RB		50	EA	\$115.00	\$5,750.00
19	A1-762-RB	RUBBER TRI-DISC: BHS #A1-762-RB		38	EA	\$115.00	\$4,370.00
20	Shaft	OCC98 STANDARD SHAFT. BUILT AS ORIGINAL. READY TO INSTALL. NEED EQUIPMENT NUMBER.		2	EA	\$5,604.23	\$11,208.46
21	Shaft	OCC98 STANDARD SHAFT. BUILT AS ORIGINAL. READY TO INSTALL. NEED EQUIPMENT NUMBER.		5	EA	\$5,604.23	\$28,021.15
22	000-0950_A	1/4"-20 X 70MM L, BINDING SCREWS FOR WOO		1175	EA	\$2.00	\$2,350.00
23	000-0951_A	1/4"-20 X 17MM L, BRONZE-PLTD STL CAP NU		1175	EA	\$1.50	\$1,762.50
24	A1-762-RB	RUBBER TRI-DISC: BHS #A1-762-RB		31	EA	\$115.00	\$3,565.00
25	Shaft	OCC98 IMPACT SHAFT. BUILT AS ORIGINAL. READY TO INSTALL. NEED EQUIPMENT NUMBER.		2	EA	\$6,404.43	\$12,808.86
26	Shaft	OCC98 STANDARD SHAFT. BUILT AS ORIGINAL. READY TO INSTALL. NEED EQUIPMENT NUMBER.		9	EA	\$5,604.23	\$50,438.07
27	000-0907_A	BEARING: DODGE, P2B-S2-115R,1 15/16"		27	EA	\$361.49	\$9,760.23
28	000-1268-0010_A	SPROCKET, SP TP DS100A15H X Q2 x 115, TD		32	EA	\$143.83	\$4,602.56
29	000-1268-0009_A	SPROCKET, SP TP: H100B15 X Q1 x 115, TD		4	EA	\$111.24	\$444.96

3592 West 5th Avenue | Eugene, OR 97402 | Tel: 541.485.0999 | Fax: 541.485.6341 | parts@bhsequip.com



Priority Service Proposal

Date: 2/5/2025
 Expiration Date: 3/7/2025

Customer: SOUTH BAYSIDE INDUSTRIES
 333 SHOREWAY ROAD
 SAN CARLOS, CA 94070

Requestor:
 Email:

Proposal No. PSQ1825338
Customer No. 18580
 Prepared By: GaryL
 Email: glee@bhsequip.com

Ship To: SOUTH BAYSIDE INDUSTRIES
 333 SHOREWAY ROAD
 SAN CARLOS, CA 94070

Contact No.

Line No.	Item #	Description	Equipment #	Qty	U/M	Unit Price	Ext. Price
30	000-1267-0005_A	CHAIN: ROLLER 29RC100 W/O&C LINK		14	EA	\$30.56	\$427.84
31	Shaft	DRS84 IMPACT SHAFT. BUILT AS ORIGINAL. READY TO INSTALL. NEED EQUIPMENT NUMBER.		2	EA	\$5,625.40	\$11,250.80
32	Shaft	DRS84 STANDARD SHAFT. BUILT AS ORIGINAL. READY TO INSTALL. NEED EQUIPMENT NUMBER.		8	EA	\$5,131.03	\$41,048.24
33	000-0907_A	BEARING: DODGE, P2B-S2-115R,1 15/16"		21	EA	\$361.49	\$7,591.29
34	000-1268-0010_A	SPROCKET, SP TP DS100A15H X Q2 x 115, TD		16	EA	\$143.83	\$2,301.28
35	000-1268-0009_A	SPROCKET, SP TP: H100B15 X Q1 x 115, TD		2	EA	\$111.24	\$222.48
36	000-1267-0005_A	CHAIN: ROLLER 29RC100 W/O&C LINK		10	EA	\$30.56	\$305.60
37	Shaft	DRS84 STANDARD SHAFT. BUILT AS ORIGINAL. READY TO INSTALL. NEED EQUIPMENT NUMBER.		8	EA	\$5,131.03	\$41,048.24
38	A1-815-RS-A	2" END DISC RUBBER		19	EA	\$42.14	\$800.66
39	A1-816-RS-A	1" END DISC RUBBER		19	EA	\$20.00	\$380.00
40	810-CS-B	POLISHER DISC - INTERLOCKING SPACER		217	EA	\$4.30	\$933.10
41	A1-800-RF-A-SVC	TRIDISC, A1-800-RF, ASSEMBLY W/ WASHER I		465	EA	\$27.40	\$12,741.00
42	A1-800-RF-A-SVC	TRIDISC, A1-800-RF, ASSEMBLY W/ WASHER I		265	EA	\$27.40	\$7,261.00
43	A1-850-RF-A-SVC	TRIDISC, A1-850-RF-A, ASSEMBLY W/ WASHER		543	EA	\$24.66	\$13,390.38



Priority Service Proposal

Date: 2/5/2025
Expiration Date: 3/7/2025

Customer: SOUTH BAYSIDE INDUSTRIES
333 SHOREWAY ROAD
SAN CARLOS, CA 94070

Requestor:
Email:

Proposal No. PSQ1825338
Customer No. 18580
Prepared By: GaryL
Email: glee@bhsequip.com

Ship To: SOUTH BAYSIDE INDUSTRIES
333 SHOREWAY ROAD
SAN CARLOS, CA 94070

Contact No.

Line No.	Item #	Description	Equipment #	Qty	U/M	Unit Price	Ext. Price
Total							\$355,959.06
<small>Terms: Net 30 Days All prices in US Dollars</small>							

Order Notes

All customer orders require a purchase order.

Please confirm this order by signing and emailing to parts@bhsequip.com or faxing all pages to 1.541.485.6341.

Prices exclude freight, handling, duties, and taxes unless otherwise noted.

Freight estimates are estimates only; freight will be billed at actual.

Any discrepancies, missing, broken or incorrect parts must be addressed with BHS within 30 days of receipt of goods.

Signed _____ Date _____ PO No. _____



Maintenance & Installation Services, Inc

11080 Rose Avenue Fontana, CA 92337 Office: 909.357.3156 Fax: 909.357.3156 CL # 872945 (A)

CUSTOMER INFORMATION

SBI- SAN CARLOS CA

REVISION P/W

Terms: Net 30

Attention: ROBERT OURIQUE

DATE: 1/7/2025

Vendors PROPOSAL T&M PROJECT

Fax:

Qty :Each	SCOPE OF SERVICES AND HOURS	LABOR HOURS	PER RATE	COST:	EXTENSION
1 LABOR	REPLACING ALL RUBBER DISC ON SHAFTS 44A & 44B NSTALL NEW SHAFTS WITH RUBBER DISC (8) DISC PER SHAFT + 5 NEW SHAFTS REQUIRING RUBBER DISC ONLY	ESTIMATED: (96) HOURS	\$155.00 P/HR	\$14,880.00	\$14,880.00
1 LABOR	46A 11 SHAFT REPLACEMENT WITH DISC-46A &48B DRS 16 SHAFT ALSO REPLACING CHAIN-SPROCKETS & BEARINGS PLUS OTHER? 26 SHAFTS TOTAL: (11) 46A (16) SHAFTS 48A & 48B	ESTIMATED: (156) HOURS	\$155.00 P/HR	\$24,180.00	\$24,180.00
1 LABOR	50A REPLACE THE FIRST THREE ROWS WITH NEW SPROCKETS-BEARINGS & CHAIN ALSO 3 SHAFTS	ESTIMATED: (48) HOURS	\$155.00 P/HR	\$7,440.00	\$7,440.00
1 LABOR	51 REPLACE THE FIRST 5 ROWS WITH NEW DISC 5 SHAFTS 11 DISC PER SHAFT	ESTIMATED: (48) HOURS	\$155.00 P/HR	\$7,440.00	\$7,440.00
1 LABOR	96B REPLACE 10 SHAFTS WITH DISC 11 DISC PER SHAFT ALSO ADD AN ADDITIONAL (20) DISCTO THE SYSTEM	ESTIMATED: (72) HOURS	\$155.00 P/HR	\$11,160.00	\$11,160.00
1 LABOR	110B REPLACE 11 SHAFTS WITH DISC 12 DISC PER SHAFT ALSO ADD AN ADDITIONAL (18) DISCTO THE SYSTEM 110B	ESTIMATED: (72) HOURS	\$155.00 P/HR	\$11,160.00	\$11,160.00
1 LABOR	126A & 126B REPLACE ALL RUBBER DISC AND SPACERS 18 EACH TOTAL SHAFTS WITH 27 DISC PER SHAFT	ESTIMATED: (108) HOURS	\$155.00 P/HR	\$16,740.00	\$16,740.00
1 LABOR	128A & 128B REPLACE 10 ROWS OF DISC AND SPACERS STARTING AFTER ROW-8 FROM THE BOTTOM UP 10 SHAFTS OF DISC 22 DISC PER SHAFT	ESTIMATED: (108) HOURS	\$155.00 P/HR	\$16,740.00	\$16,740.00
1 LABOR	612 REPLACE 6 ROWS STARTING AFTER THE 1ST ROW 6 EA COMPLETE DISC SHAFTS	ESTIMATED: (48) HOURS	\$155.00 P/HR	\$7,440.00	\$7,440.00
	ALL MATERIALS SHAFTS BEARINGS CHAINS WILL BE FURNISHED BY THE CLIENT SOUTHBAY SIDEINDUSTRIES				\$109,740.00

DATE: TBD

DELIVERY ASAP

INVOICE TBD

Respectfully,

Mike Atencio | Manager Logistics

matencio@titusservices.net

TITUS MRF SERVICES

11080 Rose Ave

Fontana, CA 92337

Office: 909.357.3156

Fax: 909.357.3166

Cell: 626.688.3078

Website: titusservices.com



A Public Agency

PUBLIC EDUCATION, OUTREACH AND LEGISLATION

Agenda Item 8



STAFF REPORT

To: RethinkWaste Board Members
From: Julia Au, Sr. Outreach, Education and Compliance Manager
Date: February 27, 2025 Board of Directors Meeting
Subject: Resolution Approving the 2025-2026 Legislative and Regulatory Platform

Recommendation

It is recommended that the RethinkWaste Board of Directors approve Resolution No. 2025-05 attached hereto authorizing the approval of the 2025-2026 Legislative and Regulatory Platform.

Summary

Adopting a legislative and regulatory platform of important topics for RethinkWaste will enable the agency to be heard in Sacramento and statewide with a loud and preemptive voice, act more swiftly on pressing and emerging legislative and regulatory issues that need prompt action, as well as help the agency prioritize our legislative resources. The 2025-2026 Legislative and Regulatory Platform (Platform) language is purposefully broad enough so that issues of importance that are not currently conceived, which may unexpectedly arise that the agency and its members may need to contribute to during this California legislative session and can still be addressed in a promptly manner. This Platform will cover one California legislative session, which covers two calendar years.

Analysis

The proposed Platform is broken out into four primary focus areas with specific topics under each section. These topic areas are important to help guide the identification of critically relevant bills and regulatory action that need attention during the legislative session that may impact the agency, our Member Agencies, etc.. Each topic area includes a line on how it meets the agency's guiding principles and/or triple zero waste vision. This document was developed by staff in conjunction with the agency's legislative and regulatory lobbyist firm, Environmental and Energy Consulting (EEC) and reviewed by the Legislative Committee.

Each year, numerous bills are proposed for legislative consideration and many more industry-specific regulations are proposed for statutory implementation; therefore, bill and regulation identification and tracking are a critically important step in the process.

Based on the approved Platform, the Executive Director and staff will work with Legislative Committee members and EEC to identify a list of industry-specific bills to track and to determine which bills to take a position on, send letters on, and if there are any potential co-sponsored legislation. To better meet the needs and time of the Committee, Board, staff and our lobbyists, the Platform will be updated at the beginning of every two year legislative session.

Background

The RethinkWaste Board of Directors last approved a Legislative and Regulatory Platform for 2023-2024 and has previously approved Platforms for 2018, 2019-2020, and 2021-2022.

Fiscal Impact

There is no additional fiscal impact for the development of this Legislative and Regulatory Platform.

Attachments:

Resolution 2025-05

Exhibit A – RethinkWaste 2025-2026 Legislative and Regulatory Platform



RESOLUTION NO. 2025-05

RESOLUTION OF THE SOUTH BAYSIDE WASTE MANAGEMENT AUTHORITY (RETHINKWASTE) BOARD OF DIRECTORS AUTHORIZING THE APPROVAL OF THE 2025-2026 LEGISLATIVE AND REGULATORY PLATFORM

WHEREAS, RethinkWaste’s newly adopted mission is to provide innovative waste reduction and diversion management through responsible and cost-effective programs that promote environmental sustainability in our communities;

WHEREAS, the goals of RethinkWaste and the environmental quality of life of our Member Agencies’ community members are strongly served by the establishment of a legislative and regulatory platform on important issues; and

WHEREAS, the adoption of a legislative platform gives RethinkWaste a strong, preemptive voice in on pressing and emerging legislative and regulatory issues and it allows staff to functionally work with agency partners and legislative and regulatory contacts to affect change that aligns with agency goals, guiding principles and its triple zero waste vision; and

NOW, THEREFORE BE IT RESOLVED that the South Bayside Waste Management Authority (RethinkWaste) hereby approves the 2025-2026 Legislative and Regulatory Platform.

PASSED AND ADOPTED by the Board of Directors of the South Bayside Waste Management Authority, County of San Mateo, State of California on the 27th day of February, 2025, by the following vote:

Agency	Yes	No	Abstain	Absent	Agency	Yes	No	Abstain	Absent
Belmont					Redwood City				
Burlingame					San Carlos				
East Palo Alto					San Mateo				
Foster City					County of San Mateo				
Hillsborough					West Bay Sanitary Dist				
Menlo Park									

I HEREBY CERTIFY that the foregoing Resolution No. 2025-05 was duly and regularly adopted at a regular meeting of the South Bayside Waste Management Authority on February 27, 2025.

ATTEST:

Adam Rak, Chairperson of
South Bayside Waste Management Authority
(RethinkWaste)

Cyndi Urman, Clerk of the Board

RethinkWaste's 2025-2026 Legislative and Regulatory Platform

Extended Producer Responsibility

- Plastics and Packaging
- Battery Collection and Recycling
- Toxics and Waste Reduction

Economic Development

- Market Development for End Products
- Healthy Soils
- Green Purchasing/ Contracting



Diversion

- Organics and Green Waste Diversion
- Food Waste Reduction and Recovery

Funding

- Infrastructure Investments
- Climate Adaptation and Mitigation

Executive Summary

A pre-approved biennial Legislative & Regulatory Platform provides RethinkWaste with a clear and concise guiding document from which to focus all targeted activities during each Legislative session to achieve agency goals and best represent its interests. All topics meet the agency's guiding principle to "advocate for environmental legislation and regulatory policies that help combat climate change and promote waste reduction." The platform is broken out into four primary focus areas, with specific topics under each section that include how each topic area will meet the agency's guiding principles and triple zero waste vision. With Legislative Committee oversight, this platform allows staff to strategically direct agency resources and marshal important external partnerships with nimble, yet highly effective urgency to deliver successful outcomes in the fast-paced and complex Sacramento legislative ecosystem.

The elements below provide the overarching direction for RethinkWaste's Legislative Committee and staff throughout the entire legislative session in the most time expeditious fashion. The Legislative & Regulatory Platform model is a longstanding tool that has been adopted by numerous governmental agencies, including the County of San Mateo, the City/County Association of Governments (C/CAG), most counties and major cities, transit districts and many special agencies. Upon Board approval, these are the four focus areas and topics our agency will work diligently to advance during this legislative session:

Extended Producer Responsibility

Extended Producer Responsibility (EPR)

Extended producer responsibility (EPR) or product stewardship is a strategy that shifts the responsibility for end-of-life management of a product or package to the manufacturer to finance the end-of-life management costs by incorporating it in the price of a product.

Support laws and regulations that require manufacturers to take responsibility for the end-of-life management of problematic (costly to handle, not easily recyclable, and toxic containing) products and packaging that shift costs away from local governments and individuals. Support efforts to implement and improve existing EPR policies and regulations to include as well as support new EPR efforts for products, including but not limited to: solar panels, vape pens, electric car batteries. Support provisions that make EPR laws effective including minimum collection rates, progressively increasing collection targets and no local preemption clause.

This meets the agency's guiding principle for environmental stewardship to "build awareness and promote responsible use and protection of the natural environment through zero waste principles and sustainable practices, in line with the highest and best use of materials."

Plastics and Packaging Reduction

Support legislation, regulations, and programs, including but not limited to implementation of SB 54, that provide a consistent approach to phasing out the sale and distribution of plastic products, materials, and packaging that cause significant land and ocean litter problems, and that are known to be carcinogenic.

This meets the agency's triple zero waste vision to "reduce plastic use and advocate for all plastics to be recyclable."

Battery Collection and Recycling Program Implementation

Support and implement legislation, regulations, and programs that ensure the safe collection, management, and processing of Li-ion batteries to reduce the serious fire, health, and safety hazard these batteries pose when improperly disposed of. This includes supporting collection programs related to loose Li-ion batteries and Li-ion batteries embedded in electronic products and zero-emission vehicles.

This meets the agency's guiding principle for environmental stewardship to "build awareness and promote responsible use and protection of the natural environment through zero waste principles and sustainable practices, in line with the highest and best use of materials."

Toxics Reduction / Household Hazardous Waste (HHW)

Support legislation that will reduce the amount of toxic chemicals released into our environment and that impact worker health. Oppose legislation that preempts or supersedes local control over household hazardous waste programs or supersedes local product stewardship/EPR ordinances and limits the role of manufacturers and producers in product stewardship programs. Oppose state legislation that weakens local ordinances without an adequately funded alternative.

This meets the agency's guiding principle for environmental stewardship to "build awareness and promote responsible use and protection of the natural environment through zero waste principles and sustainable practices, in line with the highest and best use of materials."

Economic Development

Market and Economic Development

Support legislation that promotes innovative economic development policies and programs that create green jobs and promote waste reduction. Support programs to improve California's Beverage Container Recycling Program ("Bottle bill"), including the long-term continuation and expansion of this program as well as ensuring Californians have convenient access to recycling centers. Support efforts to improve markets for compost and mulch and for recycled content products, including increasing recycled product purchasing. Support policies that develop new markets for recycled content materials and compost and policies that establish fees and funding streams for large volume or hard to recycle materials such as tires. Support legislation that promotes market development for wood and other construction and demolition materials.

This meets the agency's guiding principle for economically sustainable materials management system principle to "develop collection and processing systems that are innovative, adaptable, efficient, scalable, and resilient."

Healthy Soils

Support measures to advance the development and maintenance of healthy soils (which are expected to decline because of climate change) through the use of natural infrastructure. Support measures to increase use of compost and mulch as appropriate for new and expanded landscapes to improve soil quality and compost socks, blankets and berms as a means of flood and erosion control and soil improvement after fires.

This meets the agency’s guiding principle for environmental stewardship to “build awareness and promote responsible use and protection of the natural environment through zero waste principles and sustainable practices, in line with the highest and best use of materials.”

Green Purchasing

Support laws to purchase products and services that reduce the impact on human health and the environment through their lifecycle when compared with competing products serving the same purpose.

This meets the agency’s guiding principle for environmental stewardship to “build awareness and promote responsible use and protection of the natural environment through zero waste principles and sustainable practices, in line with the highest and best use of materials.”

Diversion

Organics and Waste Diversion

Support the diversion of recyclables and organics from landfills through implementation of AB 939 (Chapter 809, Statutes of 1989); AB 341 (Chapter 476, Statutes of 2011); AB 1826 (Chapter 727, Statutes of 2014); and SB 1383 (Chapter 395, Statutes of 2016) and support regulations that are practical for local governments to implement. Support new legislative efforts to divert waste away from landfilling and toward recycling, composting, and anaerobic digestion to support the state’s 75 percent solid waste diversion goal.

This meets the agency’s triple zero waste vision to “eliminate the disposal of recyclable and organic materials at landfills.”

Food Waste Reduction and Recovery

Support legislation to enable additional food rescue and recovery of edible food for human consumption, including expansion of good samaritan laws, increasing infrastructure, and support legislation that establishes funding for food recovery programs and develops policies for safe, but consistent food date labeling.

This meets the agency’s guiding principle for education that will “enhance environmental education to maximize public participation in materials reduction, reuse and recovery programs and services” and the agency’s triple zero waste vision to “eliminate the disposal of recyclable and organic materials at landfills.”

Funding

Infrastructure and Diversion Funding

Support new or additional funding for expanded recycling and organics processing and transition to zero emission vehicles infrastructure, which will be needed to fully implement AB 939, AB 341, AB 1826, SB 1383, SB 54 and other state laws and regulations. Support investment funding in expanded clean composting, anaerobic digestion, transition to zero emission vehicles, and recyclable

materials manufacturing to support diversion, jobs, greenhouse gas (GHG) reduction and the green economy. Specifically, supporting funding for

- The agency to implement and comply with state and local laws and regulations
- Local agencies and partner organizations to implement and comply with state and local laws and regulations, including in the form of local and infrastructure grants

This meets the agency’s guiding principles for financial sustainability and stability to “promote long-term fiscal sustainability and stability through our decisions and balance the needs of today with the needs of the future” and the economically sustainable materials management system principle to “develop collection and processing systems that are innovative, adaptable, efficient, scalable, and resilient.”

Climate Adaption and Mitigation

Support legislation that funds and advances the use of natural vegetation to adapt to flooding, fire, and drought and reduce the impact that urban areas have on the environment. This includes promoting the appropriate use of compost berms, socks and blankets to control soil erosion after fires and to address flooding, as well as the use of native plants and natural landscapes for water conservation. Support measures to expand the use of compost and mulch as ways to improve climate resiliency locally and statewide. Support legislation to reduce organics and recyclables in the landfill as a measure to reduce greenhouse gases.

This meets the agency’s guiding principle for environmental stewardship to “build awareness and promote responsible use and protection of the natural environment through zero waste principles and sustainable practices, in line with the highest and best use of materials” and the agency’s triple zero waste vision to “eliminate the disposal of recyclable and organic materials at landfills.”



A Public Agency

INFORMATIONAL ITEMS ONLY



STAFF REPORT

To: RethinkWaste Board Members
From: Julia Au, Sr. Outreach, Education and Compliance Manager
Date: February 27, 2025 Board of Directors Meeting
Subject: 2025 Legislative and Regulatory Update

Recommendation:

This staff report is for discussion purposes only and no formal action is requested of the Board of Directors.

Summary

The purpose of this report is to provide legislative and regulatory updates to the Board on the current 2025 California Legislative Session and regulatory activities being conducted by our lobbyist, Environmental and Energy Consulting (EEC).

All activities conducted from late fall to mid-February, and current list of bills EEC is tracking are listed in Attachment A for review.

On February 19, Executive Director Joe La Mariana spoke at a press conference to introduce our co-sponsored legislation, AB 762, to ban single-use disposal vapes with the co-authors Assemblymembers Irwin and Wilson and co-sponsors Californians Against Waste, California Product Stewardship Council and CALPIRG. On the same day, staff also met with legislators and legislative staff to strategically discuss our co-sponsored legislation and discuss other related waste-related concerns from an industry and local perspective.

Legislators have until February 21 to introduce legislation and EEC continues to monitor new legislation as they are introduced.

EEC also continues to monitor workshops related to the implementation of SB 54 (Plastic Pollution Prevention and Packaging Producer Responsibility Act) and AB 2440 (Responsible Battery Recycling Act of 2022).

Analysis

RethinkWaste contracts with EEC to act as the agency's legislative and regulatory lobbyist in California. EEC is a registered lobbying firm in the state of California (Lobbying ID # 1371848) and the Board approved a new contract with EEC on November 21, 2024. EEC will provide these legislative and regulatory services to RethinkWaste during the 2025-2026 Legislative Session.

Attachments:

Attachment A – EEC Legislative/Regulatory Report Update & Bill Tracking for 2025 as February 20, 2025



RethinkWaste February 2025 Legislative Report

I. Key Dates & Updates

- **December 2**, the Legislature convened for the 2025-26 Regular Session Organizational Session, as well as the First Extraordinary Session.
- **December 13** was the last day for the Secretary of State to certify all elections. California has now officially elected its most diverse set of legislators yet and approximately one-third of all legislators are new to have not previously served in the Legislature.
- **January 6** was the first day of session in the first year of a 2-year session.
- **On January 10**, Governor Newsom released his [January budget proposal](#) for FY 2025-2026, which outlines a balanced budget, consistent with what the Legislative Analyst's Office (LAO) estimated late last year. While the Governor stated a modest budget surplus of \$363 million, new commitments are not expected this Fiscal Year.
- **February 21** is the last day for legislators to introduce bills.
- Both the Assembly and the Senate have released their Committee Chair assignments. Relevant assignments include:
 - i. **Sen. Becker** as Chair of the Senate Committee on Energy, Utilities and Communications.
 - ii. **Sen. Blakespear** as Chair of the Senate Committee on Environmental Quality.
 - iii. **Sen. Allen** as Chair of the Budget Subcommittee #2 on Resources, Environmental Protection and Energy.
 - iv. **Asm. Bryan** continues as Chair of the Assembly Committee on Natural Resources.
 - v. **Asm. Connelly** as Chair of the Assembly Committee Environmental Safety and Toxic Materials.
 - vi. **Asm. Irwin** as Chair of the Joint Committee on Climate Change Policies.

II. Key Legislation

- Bill list attached.

III. Fall and Winter Activities

- EEC continued to monitor workshops related to the implementation of SB 54 and report relevant information to the RethinkWaste team.
 - RethinkWaste submitted a comment letter on the second round of draft guidelines, at the end of October.
- EEC and RethinkWaste met for a 2025 scoping meeting to review 2024 and discuss priorities for the upcoming year, on November 6, 2024.
- EEC has started tracking and monitoring relevant legislation on a daily basis.
- EEC hosted a Zero Waste Now coalition meeting on January 27th to discuss relevant legislation, timelines, and priorities for the group. The coalition will continue to meet throughout the year on a bi-monthly basis.
 - Next meeting will be on March 24.
 - EEC is reaching out to invite Zoe Heller, Director of CalRecycle to participate in a Zero Waste Now Meeting.
- EEC has been working with co-sponsors Californians Against Waste (CAW) and the California Product Stewardship Council (CPSC) to develop legislation to tackle the issue of single-use vapes.
 - This bill, AB 762, was introduced on February 18.
- EEC worked with RethinkWaste to sign on to a coalition letter in support of Zoe Heller's confirmation as Director of CalRecycle. While appointed and acting, Ms. Heller has yet to be confirmed by the Senate.
- EEC and RethinkWaste coordinated with co-sponsors on a press conference publicizing the introduction of AB 762 on February 19.
- EEC held a Lobby Day for RethinkWaste on February 19 to discuss vape legislation and other waste related concerns for local governments. Meetings were held with the following offices:
 - Assemblymember Papan
 - Assemblymember Berman (staff)
 - Senator Becker (staff)
 - Assembly Committee on Environmental Safety & Toxics Materials
 - Senate Committee on Environmental Quality

Priority 1 (High)

[AB 762](#)
[Irwin \(D\)](#)
[HTML](#)
[PDF](#)

Disposable, battery-embedded vapor inhalation device: prohibition.

Progress bar



Tracking form

Position

Sponsor

Notes

Bill information

Status: 02/19/2025 - From printer. May be heard in committee March 21.

Summary: Would prohibit, beginning January 1, 2026, a person from selling, distributing, or offering for sale a new or refurbished disposable, battery-embedded vapor inhalation device in this state. The bill would define a “disposable, battery-embedded vapor inhalation device” to mean a vaporization device that is not designed or intended to be reused, as specified. (Based on 02/18/2025 text)

Location: 02/18/2025 - Assembly PRINT

[AB 70](#)
[Aguiar-Curry \(D\)](#)
[HTML](#)
[PDF](#)

Solid waste: pyrolysis.

Progress bar



Tracking form

Position

Notes

Bill information

Status: 02/03/2025 - Referred to Com. on NAT. RES.

Summary: The California Integrated Waste Management Act of 1989 requires each city, county, and regional agency to develop a source reduction and recycling element of an integrated waste management plan. The act requires that element to include a 50% solid waste diversion requirement, as specified, and provides that up to 10% may be achieved through biomass conversion under certain conditions, with biomass conversion defined as the production of heat, fuels, or electricity by certain means from specified materials. One of the conditions for using biomass conversion to satisfy a portion of the solid waste diversion requirement is that pyrolysis not be included in the source reduction and recycling element. Pyrolysis is not defined for that purpose or for other purposes in the act. This bill would define pyrolysis as the

thermal decomposition of material at elevated temperatures in the absence or near absence of oxygen. (Based on 12/11/2024 text)

Location: 02/03/2025 - Assembly NAT. RES.

AB 80

Aguiar-Curry (D)

HTML

PDF

Carpet recycling: product stewardship for carpet: fines.

Progress bar



Tracking form

Position

Notes

Bill information

Status: 02/10/2025 - Referred to Com. on NAT. RES.

Summary: The California Integrated Waste Management Act of 1989, administered by the Department of Resources Recycling and Recovery, generally regulates the disposal, management, and recycling of solid waste. The act establishes stewardship programs for various products, including, among others, carpet. The act includes a product stewardship for carpet program and a successor carpet producer responsibility program, and requires the product stewardship for carpet program to become inoperative upon the completion of certain conditions related to the implementation of the successor carpet producer responsibility program. This bill would instead authorize a civil penalty of \$25,000 per day if the violation is intentional or knowing. (Based on 12/19/2024 text)

Location: 02/10/2025 - Assembly NAT. RES.

AB 259

Rubio, Blanca (D)

HTML

PDF

Open meetings: local agencies: teleconferences.

Progress bar



Tracking form

Position

Notes

Bill information

Status: 02/10/2025 - Referred to Com. on L. GOV.

Summary: The Ralph M. Brown Act authorizes the legislative body of a local agency to use teleconferencing, as specified, and requires a legislative body of a local agency that elects to use teleconferencing to comply with specified requirements, including that the local agency post agendas at all teleconference locations, identify each teleconference location in the notice and agenda of the meeting or proceeding, and have each teleconference location be accessible to the public. Current law, until January 1, 2026, authorizes the legislative body of a local agency to use alternative teleconferencing if, during the teleconference meeting, at least a quorum of the members of the legislative body participates in person from a singular physical location clearly identified on the agenda that is open to the public and situated within the boundaries of the territory over which the local agency exercises jurisdiction, and the

legislative body complies with prescribed requirements. Current law requires a member to satisfy specified requirements to participate in a meeting remotely pursuant to these alternative teleconferencing provisions, including that specified circumstances apply. Current law establishes limits on the number of meetings a member may participate in solely by teleconference from a remote location pursuant to these alternative teleconferencing provisions, including prohibiting such participation for more than 2 meetings per year if the legislative body regularly meets once per month or less. This bill would remove the January 1, 2026, date from those provisions, thereby extending the alternative teleconferencing procedures indefinitely. (Based on 01/16/2025 text)

Location: 02/10/2025 - Assembly L. GOV.

[AB 303](#)

[Addis \(D\)](#)

[HTML](#)

[PDF](#)

Battery energy storage facilities.

Progress bar



Tracking form

Position

Notes

Bill information

Status: 01/24/2025 - From printer. May be heard in committee February 23.

Summary: Current law, until June 30, 2029, authorizes a person proposing an eligible facility, including an energy storage system capable of storing 200 megawatthours or more of energy, to submit an application for certification with the State Energy Resources Conservation and Development Commission of the site and related facility. Current law specifies that the issuance by the commission of the certificate is in lieu of any permit, certificate, or similar document required by any state, local, or regional agency, or federal agency to the extent permitted by federal law, except as provided. Existing law establishes the procedures by which the commission is to review the application. This bill would specify that energy storage systems do not include battery energy storage systems for the above-described purposes. (Based on 01/23/2025 text)

Location: 01/23/2025 - Assembly PRINT

[AB 337](#)

[Bennett \(D\)](#)

[HTML](#)

[PDF](#)

Greenhouse Gas Reduction Fund: grant program: edible food.

Progress bar



Tracking form

Position

Notes

Bill information

Status: 02/10/2025 - Referred to Com. on NAT. RES.

Summary: Current law requires the Department of Resources Recycling and Recovery, upon appropriation, to administer a grant program to provide financial assistance to promote the in-

state development of infrastructure, food waste prevention, or other projects to reduce organic waste, sort and aggregate or process organic and other recyclable materials into new, value-added products, or divert items from disposal through enhanced reuse opportunities. Current law requires the grant program to provide eligible financial assistance for certain activities, including activities that expand and improve organic waste diversion and recycling, including, but not limited to, the recovery of food for human consumption and food waste prevention. Current law specifies eligible infrastructure projects for purposes of the program, including, but not limited to, the construction of facilities to help develop, implement, or expand edible food waste recovery operations. This bill would expand the grant program to provide financial assistance for the recovery of edible food, as specified. The bill would specify that eligible infrastructure projects includes the construction or expansion of facilities to help develop, implement, or expand edible food waste recovery operations. The bill would require the department to consider the increased amount of edible food recovery capacity that the project will create when awarding a grant for edible food recovery. (Based on 01/28/2025 text)

Location: 02/10/2025 - Assembly NAT. RES.

[AB 405](#)
[Addis \(D\)](#)
[HTML](#)
[PDF](#)

Fashion Environmental Accountability Act of 2025.

Progress bar

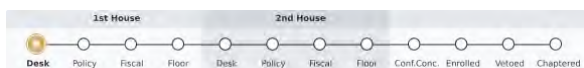

Tracking form

Position

Notes

Bill information

Status: 02/05/2025 - From printer. May be heard in committee March 7.

Summary: Current law requires the State Air Resources Board, on or before July 1, 2025, to develop and adopt regulations requiring specified partnerships, corporations, limited liability companies, and other business entities with total annual revenues in excess of \$1,000,000,000 and that do business in California, defined as “reporting entities,” to publicly disclose starting in 2026 or on a date to be determined by the state board, and annually thereafter, their scope 1 and scope 2 greenhouse gas emissions, as defined, and, starting in 2027 and annually thereafter, their scope 3 greenhouse gas emissions, as defined, for the reporting entity’s prior fiscal year, as provided. This bill would enact the Fashion Environmental Accountability Act of 2025 and would require fashion sellers to carry out effective environmental due diligence, as provided. The bill would vest the Department of Toxic Substances Control with jurisdiction over fashion sellers’ environmental due diligence pertaining to chemical management and wastewater testing. The bill would vest the state board with jurisdiction over a fashion seller’s environmental due diligence pertaining to emissions of greenhouse gases. The bill would require a fashion seller, in carrying out its effective environmental due diligence, to comply with certain environmental guidelines that, at a minimum, require the fashion seller to, among other things, embed responsible business conduct in its policies and management systems, identify areas of significant risks of societal and ecological harms from its own activities and its supply chain relationships, identify, prioritize, and assess the significant potential and actual adverse impacts of those risks, and cease, prevent, or mitigate those risks, as provided. The bill would require a fashion seller, beginning July 1, 2027, and annually thereafter, to submit to the department and the state board an Environmental Due Diligence Report pertaining to the effective environmental due diligence performed by the fashion seller for the prior calendar year, as provided. The bill would require a fashion seller, in carrying out its environmental due diligence, to establish a quantitative baseline for their emissions of greenhouse gases and targets for reductions in the emissions of greenhouse gases in the

near-term and long-term covering their scopes 1, 2, and 3 emissions, as provided. (Based on 02/04/2025 text)

Location: 02/04/2025 - Assembly PRINT

[AB 411](#)

[Papan \(D\)](#)

[HTML](#)

[PDF](#)

Livestock carcasses: disposal: composting.

Progress bar



Tracking form

Position

Notes

Bill information

Status: 02/05/2025 - From printer. May be heard in committee March 7.

Summary: Current law prohibits a dead animal hauler or any other person from transporting a dead animal to any place, other than to certain specified facilities or destinations, unless a certain waiver is granted by the State Veterinarian, as specified. The Department of Resources Recycling and Recovery has adopted a regulation that prohibits the composting of unprocessed mammalian tissue except when received from certain sources. This bill would, notwithstanding those prohibitions, authorize any part of a livestock carcass resulting from a routine livestock mortality event or on-farm processing to be composted if certain requirements are met, including, among others, that the composting is conducted in accordance with best management practices for livestock composting approved by the Secretary of Food and Agriculture. (Based on 02/04/2025 text)

Location: 02/04/2025 - Assembly PRINT

[AB 473](#)

[Wilson \(D\)](#)

[HTML](#)

[PDF](#)

Environmental advertising: recyclability.

Progress bar

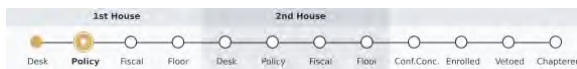

Tracking form

Position

Notes

Bill information

Status: 02/18/2025 - Referred to Com. on NAT. RES.

Summary: Current law prohibits a person from offering for sale, selling, distributing, or importing into the state any product or packaging for which a deceptive or misleading claim about the recyclability of the product or packaging is made. Current law provides that a product or packaging that displays a chasing arrows symbol, among other symbols, statements, or directions, is deemed to be a deceptive or misleading claim unless (1) the product or packaging is considered recyclable in the state pursuant to specified criteria and (2) is of a material type and form that routinely becomes feedstock used in the production of new products or packaging, except as provided. Current law, notwithstanding specified criteria, provides that a product or packaging is recyclable in the state if the product or packaging is

part of, and in compliance with, a program established pursuant to state or federal law governing the recyclability or disposal of that product or packaging, as provided. This bill would delete the latter provision and would, notwithstanding specified provisions, require, before January 1, 2027, that a product or packaging that is a covered material, as defined, be considered recyclable in the state if the producer is approved by a producer responsibility organization to participate in that organization. (Based on 02/06/2025 text)

Location: 02/18/2025 - Assembly NAT. RES.

[AB 476](#) [González, Mark \(D\)](#) [HTML](#) [PDF](#)

Junk dealers and recyclers: nonferrous metals.

Progress bar



Tracking form

Position

Notes

Bill information

Status: 02/11/2025 - From printer. May be heard in committee March 13.

Summary: Current law requires junk dealers and recyclers to keep a written record of all sales and purchases made in the course of their business, including the place and date of each sale or purchase of junk, as defined. Current law requires the written record to include a statement indicating either that the seller of the junk is the owner of it, or the name of the person they obtained the junk from, as shown on a signed transfer document. Current law prohibits a junk dealer or recycler from providing payment for nonferrous materials until the junk dealer or recycler obtains a copy of a valid driver's license of the seller or other specified identification. Current law requires a junk dealer or recycler to preserve the written record for at least 2 years. Existing law makes a violation of the recordkeeping requirements a misdemeanor. This bill, among other changes, would require junk dealers and recyclers to include additional information in the written record, including the time and amount paid for each sale or purchase of junk made, and the name of the employee handling the transaction. The bill would require the statement referenced above indicating ownership or the name of the person from whom the seller obtained the junk from to be signed and would require the statement to include specified information, including the legal name, date of birth, and place of residence of the seller. The bill would impose additional requirements on a junk dealer or recycler purchasing nonferrous metals, including obtaining proof of ownership showing the seller has lawful possession or lawful ownership of the nonferrous metals, as specified. The bill would prohibit a junk dealer or recycler from purchasing nonferrous metals from a person under 18 years of age. (Based on 02/10/2025 text)

Location: 02/10/2025 - Assembly PRINT

[AB 555](#) [Jackson \(D\)](#) [HTML](#) [PDF](#)

Air resources: regulatory impacts: transportation fuel costs.

Progress bar



Tracking form

Position

Notes

Bill information

Status: 02/13/2025 - From printer. May be heard in committee March 15.

Summary: Would require the State Air Resources Board, on a quarterly basis, to submit to the relevant policy committees of the Legislature a report providing data and describing the impacts of its regulations of transportation fuels on the prices of those fuel to California consumers. (Based on 02/12/2025 text)

Location: 02/12/2025 - Assembly PRINT

[AB 574](#)
[González, Mark \(D\)](#)
[HTML](#)
[PDF](#)

Hazardous waste: facilities: permits.

Progress bar



Tracking form

Position

Spot

Notes

Bill information

Status: 02/13/2025 - From printer. May be heard in committee March 15.

Summary: Current law, as part of the hazardous waste control laws, requires a facility handling hazardous waste to obtain a hazardous waste facilities permit from the Department of Toxic Substances Control. Current law requires an application for a hazardous waste facilities permit or other grant of authorization to use and operate a hazardous waste facility to include a disclosure statement, as specified. This bill would make a nonsubstantive change to the requirement that the application include a disclosure statement. (Based on 02/12/2025 text)

Location: 02/12/2025 - Assembly PRINT

[AB 599](#)
[Connolly \(D\)](#)
[HTML](#)
[PDF](#)

Hazardous waste: classification and alternative management standards: notice of change.

Progress bar



Tracking form

Position

Notes

Bill information

Status: 02/14/2025 - From printer. May be heard in committee March 16.

Summary: Current law requires the Department of Toxic Substances Control, before adopting building standards or adopting or revising other standards and regulations for the handling, processing, storing, use, recycling, and disposal of hazardous and extremely hazardous wastes, to hold at least one public hearing in Sacramento, or in a city within the area of the state to be affected by the proposed regulations, as provided. This bill would, if the department proposes to reclassify wastes or adopt alternative management standards for

regulated waste, require the department to take all necessary and authorized steps required by law to facilitate full public notification and review of state, regional, and local facility entitlements, to enable local community input regarding the proposed changes to the classification of wastes or the alternative management standards. (Based on 02/13/2025 text)

Location: 02/13/2025 - Assembly PRINT

AB 620

Jackson (D)

HTML

PDF

Medium- and Heavy-Duty Zero-Emission Vehicle Fleet Purchasing Assistance Program: rental vehicles.

Progress bar



Tracking form

Position

Notes

Bill information

Status: 02/14/2025 - From printer. May be heard in committee March 16.

Summary: Current law establishes the Medium- and Heavy-Duty Zero-Emission Vehicle Fleet Purchasing Assistance Program (program) within the Air Quality Improvement Program to make financing tools and nonfinancial supports available to operators of medium- and heavy-duty vehicle fleets to enable those operators to transition their fleets to zero-emission vehicles. This bill, for any regulation adopted to develop or implement the program, or other regulations that are regarding the procurement or use of medium- and heavy-duty zero-emission vehicles by a public or private fleet, would require the state board to consider specified things, including, among other things, the environmental and supply chain benefits of renting medium- and heavy-duty zero-emission vehicles compared to procuring them. (Based on 02/13/2025 text)

Location: 02/13/2025 - Assembly PRINT

AB 643

Wilson (D)

HTML

PDF

Climate change: short-lived climate pollutants: organic waste reduction.

Progress bar



Tracking form

Position

Spot

Notes

Bill information

Status: 02/14/2025 - From printer. May be heard in committee March 16.

Summary: Current law establishes methane emissions reduction goals that include a target to reduce landfill disposal of organics by 75% of the 2014 level of the statewide disposal of organic waste by 2025. Current law requires the Department of Resources Recycling and Recovery, in consultation with the State Air Resources Board, to adopt regulations to achieve the organic waste reduction goals. Current law specifies that the adopted regulations do not limit the authority of local jurisdictions to adopt, implement, or enforce additional requirements on

organic waste reduction. This bill would make a nonsubstantive change to the provision related to the authority of local jurisdictions. (Based on 02/13/2025 text)

Location: 02/13/2025 - Assembly PRINT

AB 663

McKinnor (D)

HTML

PDF

Hydrofluorocarbon gases: sale and distribution prohibition: exemptions.

Progress bar



Tracking form

Position

Notes

Bill information

Status: 02/15/2025 - From printer. May be heard in committee March 17.

Summary: Current law prohibits a person from offering for sale or distribution, or otherwise entering into commerce in the state, bulk hydrofluorocarbons or bulk blends containing hydrofluorocarbons that exceed a specified global warming potential limit beginning January 1, 2025, and lower global warming potential limits beginning January 1, 2030, and January 1, 2033. Current law exempts from that prohibition hydrofluorocarbons that are reclaimed, as defined under a specified federal regulation. Under existing law, a violation of these prohibitions is a crime. This bill would eliminate the exemption for reclaimed hydrofluorocarbons and would instead create a new exemption for certified reclaimed refrigerants, as defined. (Based on 02/14/2025 text)

Location: 02/14/2025 - Assembly PRINT

AB 696

Ransom (D)

HTML

PDF

Lithium-ion vehicle batteries: emergencies: advisory group.

Progress bar

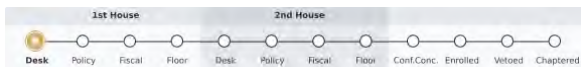

Tracking form

Position

Notes

Bill information

Status: 02/15/2025 - From printer. May be heard in committee March 17.

Summary: Would require the Secretary for Environmental Protection, on or before July 1, 2026, to convene the Lithium-Ion Car Battery Advisory Group to review, and advise the Legislature on, policies pertaining to the handling and disposal of lithium-ion vehicle batteries in an emergency capacity. The bill would require the secretary to appoint members to the advisory group from specified departments, vocations, and organizations. The bill would require the advisory group to meet at least quarterly until July 1, 2028, and to consult with universities and research institutions that have conducted research in the area of battery recycling, with manufacturers of electric and hybrid vehicles, and with the recycling industry. The bill would require the group to submit, on or before July 1, 2028, policy recommendations to the Legislature aimed at ensuring that best standards and practices are created that allow first

responders to respond to lithium-ion vehicle battery emergencies in a safe and efficient manner. The bill would repeal these provisions on January 1, 2029. (Based on 02/14/2025 text)

Location: 02/14/2025 - Assembly PRINT

AB 716

Carrillo (D)

HTML

PDF

Energy: Hydrogen Program.

Progress bar



Tracking form

Position

Spot

Notes

Bill information

Status: 02/15/2025 - From printer. May be heard in committee March 17.

Summary: Current law requires the State Energy Resources Conservation and Development Commission to establish and administer the Hydrogen Program to provide financial incentives to eligible instate hydrogen projects for the demonstration or scale-up of the production, processing, delivery, storage, or end use of hydrogen. This bill would make nonsubstantive changes to that requirement. (Based on 02/14/2025 text)

Location: 02/14/2025 - Assembly PRINT

AB 883

Lowenthal (D)

HTML

PDF

California Public Records Act.

Progress bar



Tracking form

Position

Notes

Bill information

Status: 02/19/2025 - Read first time. To print.

Summary: The California Public Records Act requires state and local agencies to make their records available for public inspection, unless an exemption from disclosure applies. That act prohibits a state or local agency from publicly posting the home address, telephone number, or both the name and assessor parcel number associated with the home address of any elected or appointed official on the internet without first obtaining the written permission of that individual. This bill would make nonsubstantive changes to that provision. (Based on 02/19/2025 text)

Location: 02/19/2025 - Assembly PRINT

AB 905

Pacheco (D)

HTML

PDF

Public bodies: general obligation bonds: disclosure requirements.

Progress bar



Tracking form

Position

Notes

Bill information

Status: 02/19/2025 - Read first time. To print.

Summary: Current law authorizes the governing body of a public body to authorize the issuance of bonds pursuant to a resolution, indenture, agreement, or other instrument providing for the issuance of bonds. Current law defines a “public body” to mean, among other entities, a county, city, or city and county. Current law requires a governing body of a public body, prior to the issuance of certain bonds with a term of greater than 13 months, to obtain and disclose specified information regarding the bonds in a meeting open to the public. Current law requires the information to be obtained as a good faith estimate from an underwriter, financial advisor, or private lender or from a third-party borrower, as specified, if the public body issuing bonds is a conduit financing provider, as defined. The State General Obligation Bond Law generally sets forth the procedures for the issuance and sale of bonds governed by its provisions and for the disbursement of the proceeds of the sale of those bonds. Current law requires any state bond measure approved on or after January 1, 2004, to be subject to an annual reporting process, with the head of the lead state agency administering the bond proceeds reporting certain information about the projects being funded to the Legislature and the Department of Finance. Current law allows this information to be provided on the agency’s internet website or the state’s open data portal under certain circumstances. This bill would require the governing body of a public body, for general obligation bonds approved by voters on and after January 1, 2026, to develop and publicly disclose, within 90 days after approval by the voters, specified information about the objectives of the bond expenditure and related data. (Based on 02/19/2025 text)

Location: 02/19/2025 - Assembly PRINT

[SB 45](#)
[Padilla \(D\)](#)
[HTML](#)
[PDF](#)

Recycling: beverage containers: tethered plastic caps.

Progress bar



Tracking form

Position

Notes

Bill information

Status: 01/29/2025 - Referred to Com. on E.Q.

Summary: The California Beverage Container Recycling and Litter Reduction Act, which is administered by the Department of Resources Recycling and Recovery, is established to promote beverage container recycling. The act defines “beverage container” to mean the individual, separate bottle, can, jar, carton, or other receptacle, however denominated, in which a beverage is sold, and that is constructed of metal, glass, or plastic, or other material, or any combination of these materials, but does not include cups or other similar open or loosely sealed receptacles. Current law authorizes the department, subject to the availability of funds, to pay

a quality incentive payment of up to \$180 per ton to qualified recyclers for thermoform plastic containers diverted from curbside recycling programs, as provided. This bill would delete that authorization. The bill would instead require, on and after January 1, 2027, beverage containers, as defined, intended for sale in this state, to have a cap that is tethered to the container that prevents the separation of the cap from the container when the cap is removed from the container by the consumer. The bill would exempt, until January 1, 2028, any type of beverage container with a recycling rate of better than 70% for calendar years 2022 and 2023, as determined by the department, from compliance with that requirement. The bill would exempt beverage containers with a capacity of 3 liters or more from the scope of the bill. (Based on 12/12/2024 text)

Location: 01/29/2025 - Senate E.Q.

[SB 231](#) [Seyarto \(R\)](#) [HTML](#) [PDF](#)

California Environmental Quality Act: guidelines.

Progress bar



Tracking form

Position

Notes

Bill information

Status: 02/05/2025 - Referred to Com. on E.Q.

Summary: The California Environmental Quality Act (CEQA) requires a lead agency to prepare a mitigated negative declaration for a project that may have a significant effect on the environment if revisions in the project would avoid or mitigate that effect and there is no substantial evidence that the project, as revised, would have a significant effect on the environment. CEQA requires the Office of Land Use and Climate Innovation, formerly named the Office of Planning and Research, to prepare and develop, and the Secretary of the Natural Resources Agency to certify and adopt, guidelines for the implementation of CEQA. CEQA requires the guidelines to specifically include criteria for public agencies to follow in determining whether or not a proposed project may have a significant effect on the environment. This bill would require, on or before July 1, 2027, the Office of Land Use and Climate Innovation to prepare and develop, and the Secretary of the Natural Resources Agency to certify and adopt, guidelines in Appendix O of the CEQA guidelines to establish best practices for public agencies to follow in determining whether or not a proposed project may have a significant effect on the environment when completing Appendix G of the CEQA guidelines. The bill would require the best practices to consider, and include identifiable thresholds of significance based on, specified state and federal environmental laws. The bill would authorize the office, in developing those guidelines, to consult with local, regional, state, and federal agencies that have authority and expertise on those subjects. (Based on 01/28/2025 text)

Location: 02/05/2025 - Senate E.Q.

[SB 235](#) [McNerney \(D\)](#) [HTML](#) [PDF](#)

Recycling: precious metals and critical minerals: report.

Progress bar

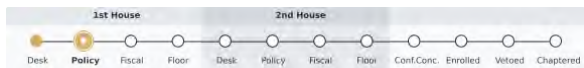

Tracking form

Position
Notes

Bill information

Status: 02/05/2025 - Referred to Com. on E.Q.

Summary: Would require the Department of Resources Recycling and Recovery to draft and submit a report to the Legislature on or before January 1, 2028, relating to the in-state collection, recycling, reuse, and stockpiling for domestic consumption of precious metals, critical minerals, as defined, and other similar valuable materials as reasonably decided by the department, contained within products in the state, as specified. The bill would require the department to provide opportunities for public input and to perform outreach to potentially interested parties, as specified. (Based on 01/29/2025 text)

Location: 02/05/2025 - Senate E.Q.

[SB 279](#)
[McNerney \(D\)](#)
[HTML](#)
[PDF](#)

Solid waste: compostable materials.

Progress bar



Tracking form

Position
Notes

Bill information

Status: 02/14/2025 - Referred to Com. on E.Q.

Summary: Current law requires the Department of Resources Recycling and Recovery to adopt and revise regulations setting forth minimum standards for composting, in accordance with law. Current regulations require all compostable materials handling activities to obtain a permit prior to commencing operations and to comply with specified requirements. Current regulations specify 4 regulatory tiers for composting operations, with different requirements for each tier. The 4 tiers are excluded, enforcement agency notification, registration permit, and full solid waste facility permit. In the excluded tier, existing regulations specify the “excluded activities” that do not constitute compostable material handing operations or facilities and, therefore, are not subject to permit requirements or other regulatory requirements. One of the excluded activities is the composting of green material, agricultural material, food material, and vegetative food material, alone or in combination, if the total amount of feedstock and compost onsite at any one time does not exceed 100 cubic yards and 750 square feet. This bill would require that the total amount of feedstock and compost onsite at any one time not exceed 500 cubic yards instead of the 100 cubic yards and 750 square feet in the regulations. (Based on 02/05/2025 text)

Location: 02/14/2025 - Senate E.Q.

[SB 285](#)
[Becker \(D\)](#)
[HTML](#)
[PDF](#)

Net zero greenhouse gas emissions goal: carbon dioxide removal: regulations.

Progress bar



Tracking form

Position
Notes

Bill information

Status: 02/14/2025 - Referred to Com. on E.Q.

Summary: The California Global Warming Solutions Act of 2006 establishes the State Air Resources Board as the state agency responsible for monitoring and regulating sources emitting greenhouse gases. The act requires the state board to approve a statewide greenhouse gas emissions limit equivalent to the statewide greenhouse gas emissions level in 1990 to be achieved by 2020 and to ensure that statewide greenhouse gas emissions are reduced to at least 40% below the 1990 level by 2030. The act requires the state board to prepare and approve a scoping plan for achieving the maximum technologically feasible and cost-effective reductions in greenhouse gas emissions and to update the scoping plan at least once every 5 years. Current law requires the state board, as part of its scoping plan, to establish specified carbon dioxide removal targets for 2030 and beyond. This bill would, for the purpose of meeting, or tracking progress against, any state requirement to achieve net zero emissions of greenhouse gases, or for the purpose of reporting offsets against any of a reporting entity's greenhouse gas emissions as part of reporting required pursuant the Climate Corporate Data Accountability Act, authorize only qualified carbon dioxide removal, as defined, to be used to reduce the state's or an entity's greenhouse gas emissions and would require qualified carbon dioxide removal used for those purposes to meet certain requirements, as specified. (Based on 02/05/2025 text)

Location: 02/14/2025 - Senate E.Q.

[SB 302](#)
[Padilla \(D\)](#)
[HTML](#)
[PDF](#)

Personal Income Tax Law and Corporation Tax Law: exclusions: environmental credits.

Progress bar



Tracking form

Position
Notes

Bill information

Status: 02/19/2025 - Referred to Com. on REV. & TAX.

Summary: The Personal Income Tax Law and the Corporation Tax Law, in conformity with federal income tax law, generally defines "gross income" as income from whatever source derived, except as specifically excluded, and provides various exclusions from gross income. Current federal law authorizes an applicable entity, as defined, to receive a refund for specified environmental credits against the taxes imposed under federal law and excludes a refund payment made pursuant to that law from gross income. Current federal law also authorizes an eligible taxpayer, as defined, to transfer the value of that refundable credit and exempts from gross income payment received by the transferor as consideration for the transfer. Current federal law prohibits the transferee from deducting the amount paid as consideration for the transfer. This bill, in conformity with federal law, for taxable years beginning on or after January 1, 2023, would exclude from gross income a refund payment made for the specified federal environmental credits described above and any payment received by a transferor as consideration for a transfer, as provided. (Based on 02/10/2025 text)

Location: 02/19/2025 - Senate REV. & TAX

[SB 328](#)[Grayson \(D\)](#)[HTML](#)[PDF](#)**Hazardous waste control: investigations.****Progress bar****Tracking form****Position****Notes****Bill information****Status:** 02/19/2025 - Referred to Com. on RLS.

Summary: Current law authorizes the Department of Toxic Substances Control to report findings and results of an investigation the department undertakes pertaining to the hazardous waste control laws, distribute the information it considers necessary for specified purposes, and publish reports summarizing or containing any order of the Director of Toxic Substances Control or any judgment or court order rendered pursuant to the hazardous waste control laws, as provided. This bill would make nonsubstantive changes to those authorizations. (Based on 02/11/2025 text)

Location: 02/11/2025 - Senate RLS.[SB 348](#)[Hurtado \(D\)](#)[HTML](#)[PDF](#)**State Air Resources Board: Low-Carbon Fuel Standard.****Progress bar****Tracking form****Position****Notes****Bill information****Status:** 02/19/2025 - Referred to Com. on RLS.

Summary: The California Global Warming Solutions Act of 2006 requires the State Air Resources Board to adopt rules and regulations, as provided, to achieve the maximum technologically feasible and cost-effective greenhouse gas emissions reductions to ensure that the statewide greenhouse gas emissions are reduced to at least 40% below the statewide greenhouse gas emissions limit, as defined, no later than December 31, 2030. Pursuant to the act, the state board has adopted the Low-Carbon Fuel Standard, or regulations. This bill would state the intent of the Legislature to enact future legislation that would, among other things, require the board to revise the Low-Carbon Fuel Standard program, as provided. The bill would make related findings and declarations. (Based on 02/12/2025 text)

Location: 02/12/2025 - Senate RLS.[SB 404](#)[Caballero \(D\)](#)[HTML](#)[PDF](#)**Hazardous materials: metal shredding facilities.****Progress bar**



Tracking form

Position

Notes

Bill information

Status: 02/18/2025 - From printer. May be acted upon on or after March 17.

Summary: Current law authorizes the Department of Toxic Substances Control (DTSC), in consultation with the Department of Resources Recycling and Recovery, the State Water Resources Control Board, and affected local air quality management districts, to adopt regulations to establish management standards for metal shredding facilities for hazardous waste management activities within DTSC’s jurisdiction, as provided. Current law provides that treated metal shredder waste that is managed in accordance with those regulations is deemed to be solid waste, and not hazardous waste, as provided. This bill would repeal those provisions and would establish a comprehensive scheme for the regulation of metal shredding facilities. The bill would prohibit an owner or operator from operating a metal shredding facility, as defined, in the state unless they have a permit from DTSC or are deemed to have a permit. The bill would prescribe the requirements for obtaining a permit, for being deemed to have a permit, for operating a metal shredding facility, and for transporting certain materials related to metal shredding, as specified. The bill would provide that certain materials related to metal shredding are not hazardous waste if they meet specified requirements. The bill would require any report required to be submitted by a metal shredding facility pursuant to a permit issued to be signed by the owner or operator and be certified under penalty of law, including criminal penalties, as specified. Because the bill would expand the scope of a crime, the bill would impose a state-mandated local program. (Based on 02/14/2025 text)

Location: 02/14/2025 - Senate RLS.

[SB 496](#)
[Hurtado \(D\)](#)
[HTML](#)
[PDF](#)

Advanced Clean Fleets Regulation: appeals advisory committee: exemptions.

Progress bar



Tracking form

Position

Notes

Bill information

Status: 02/19/2025 - Introduced. Read first time. To Com. on RLS. for assignment. To print.

Summary: The California Global Warming Solutions Act of 2006 establishes the state board as the state agency responsible for monitoring and regulating sources emitting greenhouse gases and requires the state board to adopt rules and regulations to achieve the maximum technologically feasible and cost-effective greenhouse gas emission reductions from those sources. This bill would require the state board to establish the Advanced Clean Fleets Regulation Appeals Advisory Committee by an unspecified date for purposes of reviewing appeals of denied requests for exemptions from the requirements of the Advanced Clean Fleets Regulation. The bill would require the committee to include representatives of specified governmental and nongovernmental entities. The bill would require the committee to meet monthly and would require recordings of its meetings to be made publicly available on the state board’s internet website. The bill would require the committee to consider, and make a

recommendation on, an appeal of an exemption request denial no later than 60 days after the appeal is made. The bill would require specified information relating to the committee's consideration of an appeal to be made publicly available on the state board's internet website. The bill would require the state board to consider a recommendation of the committee at a public meeting no later than 60 days after the recommendation is made. (Based on 02/19/2025 text)

Location: 02/19/2025 - Senate RLS.

[SB 501](#) [Allen \(D\)](#) [HTML](#) [PDF](#)

Household Hazardous Waste Producer Responsibility Act.

Progress bar

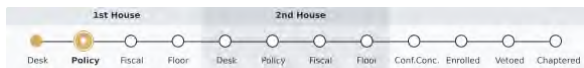

Tracking form

Position

Notes

Bill information

Status: 02/19/2025 - Introduced. Read first time. To Com. on RLS. for assignment. To print.
Summary: This bill would create a producer responsibility program for products containing household hazardous waste and would require a producer responsibility organization (PRO) to ensure the safe and convenient collection and management of covered products at no cost to consumers or local governments. The bill would define "covered product" to mean a consumer product that is ignitable, toxic, corrosive, or reactive, or that meets other specified criteria. The bill would require a producer of a covered product to register with the producer responsibility organization (PRO), which would be required to develop and implement a producer responsibility plan for the collection, transportation, and the safe and proper management of covered products. The bill would require Department of Toxic Substances Control (DTSC) to adopt regulations to implement the program with an effective date no earlier than July 1, 2028. (Based on 02/19/2025 text)

Location: 02/19/2025 - Senate RLS.

Total Measures: 31
Total Tracking Forms: 31



STAFF REPORT

To: RethinkWaste Board Members
From: Reagan Chung, Recycling and Compliance Program Manager
Date: February 27, 2025 Board of Directors Meeting
Subject: Update on SB 1383 Compliance Program on behalf of RethinkWaste Member Agencies

Summary

As detailed in the 2021 RethinkWaste SB 1383 Memorandum of Understanding authorized by the RethinkWaste Board of Directors and RethinkWaste Member Agencies, RethinkWaste staff has been delegated a significant portion of the SB 1383 program responsibilities. This is an informational report with no action required.

Staff has updates on the following item:

1. SB 1383 Compliance Progress

RethinkWaste staff concluded 2024 by sending a total of 869 waiver decision letters. Of that, 613 were approval letters and 256 were denial letters. Table 1 documents how many approved and denied letters were sent in each month in 2024. Please note that in February (*), no waivers were mailed out due to a new waiver process being implemented. RethinkWaste and Recology continue to contact all residential, commercial, and multi-family generators who are not currently in compliance with SB 1383 requirements. RethinkWaste staff continues outreach efforts to boost SB 1383 compliance numbers throughout the service area. Topics covered included SB 1383 requirements, proper sorting techniques, how to comply with SB 1383, how to sign up for De Minimis and Physical Space Waivers, and who to contact for further assistance.

Since the start of 2025, staff conducted two SB 1383 compliance presentations. One to the Downtown San Mateo Association (DSMA) and another to the City of Burlingame’s Economic Development Subcommittee and hopes to provide more compliance presentations in the future to other organizations to bridge the importance of SB 1383 compliance.

Table 1

Year	Month	Approved	Denied
2024	January	201	77
	February*	0	0
	March	37	12
	April	83	19
	May	28	12
	June	6	3
	July	12	9
	August	37	27

	September	56	28
	October	76	36
	November	61	26
	December	16	7
	Total	613	256

2. Enforcement

Enforcement for SB 1383 started on January 1, 2024, which means jurisdictions must now issue a Notice of Violation (NOV) requiring compliance within 60 days for all non-compliant generators. If after 60 days, the entity is still not in compliance, the jurisdiction shall impose penalties. SB 1383 NOV letters in the first year are typically meant to require compliance, educate all non-compliant entities, and provide time for entities to correct their mistakes without facing immediate penalties. However, these notices should not be ignored, as continuing violations could lead to fines and more severe penalties in future years.

Conducting SB 1383 enforcement has not been a responsibility delegated to RethinkWaste by Member Agencies, though RethinkWaste staff has and will continue to support Member Agencies as needed as SB 1383 implementation moves from outreach and education to enforcement. RethinkWaste staff continues to work with Member Agency staff on post-NOV letter enforcement structures.

Table 2 documents the full number of NOV and warning letters that were sent by RethinkWaste on behalf of each Member Agency in 2024 and early 2025:

Table 2

Member Agency	Batch 1 Number of Letters	Batch 1 Mail Date	Batch 2 Number of Letters	Batch 2 Mail Date	Batch 3 Number of Letters	Batch 3 Mail Date
Belmont	56	11/26/2024	-	-	-	-
Burlingame	96	6/13/2024	92	7/11/2024	89	8/15/2024
East Palo Alto	25	7/25/2024	19	11/5/2024	-	-
Foster City	4	10/3/2024	2	12/3/2024	-	-
Hillsborough	<i>Already SB 1383 Compliant</i>					
Menlo Park	128	12/24/2024	90	1/9/2025		
Redwood City	183	10/3/2024	183	10/25/2024	-	-
San Mateo	188	8/16/2024	188	9/4/2024	187	10/23/2024
San Carlos	87	6/13/2024	87	7/11/2024	85	8/15/2024
San Mateo County	198	7/25/2024	-	-	-	-
West Bay Sanitary District	1	6/20/2024	-	-	-	-

* The City of San Mateo completed their NOV letter mailing in October of 2024 and will be mailing second rounds of NOV in 2025.

In addition, staff collaborated with Recology to create a 2025 NOV letter mailing schedule, the mailing schedule is as follows:

- Q1: January – March: Burlingame, Belmont

- Q2: April – June: San Carlos, East Palo Alto, Foster City, West Bay Sanitary District, Hillsborough *(if need)*
- Q3: July – September: Redwood City
- Q4: October – November: Unincorporated County, Menlo Park

Background

September 2016, SB 1383 (Lara, Chapter 395, Statutes of 2016) established statewide methane emissions reduction targets in an effort to reduce emissions of short-lived climate pollutants in various sectors of California's economy. It includes statewide goals to reduce the disposal of organic waste and recover edible food for human consumption. To accomplish these statewide goals, SB 1383 regulations were developed, which were approved on November 3rd, 2020, and include prescriptive requirements for jurisdictions related to recycling and organics collection, inspection, and enforcement policies and programs and edible food recovery. RethinkWaste and its Member Agencies need to comply with nearly all SB 1383 requirements by January 1, 2022, with the significant exception that enforcement actions do not need to commence until January 1, 2024.

More information regarding SB 1383 can be found online at www.calrecycle.ca.gov/organics/slcp/.

STAFF REPORT

To: RethinkWaste Board Members
From: John Mangini, Senior Finance Manager
Date: February 27, 2025, Board of Directors Meeting
Subject: 2025 Finance and Rate Setting Calendar

Recommendation

This is an informational report, and no action is necessary.

Summary

The purpose of this staff report is to keep the Board and Member Agency staff informed on the schedule of important financial and rate setting events in 2025. This staff report is updated as necessary and included in the Board packet each month.

2025 Schedule of Finance, Contractor Compensation and Rate Adjustment Activities:

March 2025

- Recology submission of the unaudited 2024 Revenue Reconciliation Report (*Due: March 31*)

June 2025

- Mid-year review of the adopted FY2025 RethinkWaste Operating Budget (*June 10 Finance Committee; June 26-BOD*)
- Recology's 2026 Compensation Application submission to the RethinkWaste/Member Agencies (*Due: June 16*)
- RethinkWaste issues Member Agency letters requesting formal confirmation on their estimated 2026 Member Agency fees (e.g., franchise fees) to be included in their 2026 solid waste rates.
- Review of Recology's Revenue Reconciliation Report from the independent Financial Systems audit report.
- Approval of the FY2024 Audited Financial Statements.

July 2025

- RethinkWaste / Member Agency submit comments to Recology on its 2026 Compensation Application (*Due: July 1*)
- South Bay Industries (SBI) 2026 Compensation Application submission to RethinkWaste (*Due: July 1*)
- Recology revised 2026 Compensation Application submission to RethinkWaste/Member Agencies (*Due: July 15*)
- RethinkWaste issues the following reports to the Board and Member Agency staff for review and comment:
 - 1. Estimated 2025 and 2026 residential and commercial base revenue
 - 2. Estimated collected tonnage for 2025 and 2026.
 - 3. Summary of 2026 Member Agency fees to be used in the 2026 cost projections based on Member Agency feedback.

August 2025

- RethinkWaste issues the Draft Report Reviewing Recology's 2026 Compensation Application, recommended total Revenue Requirement, and Rate Adjustment (*Due: August 11*) Comments due from Member Agencies on draft Reports Reviewing Recology's 2026 Compensation Application (*Due: August 22*)

September 2025

- RethinkWaste TAC Meeting reviewing Pre-Final Report Reviewing Recology's 2026 Compensation Application (*September 11*).
- RethinkWaste issues Amended Final Report Reviewing Recology's 2026 Compensation Application including the recommended total Collection Rate Adjustment for 2026. (*September BOD Packet*)
- Approval of Recology 2026 Compensation Application and total recommended Revenue Requirement (*September 18 BOD Meeting*)

October 2025

- Finance Committee review of RethinkWaste's DRAFT FY2026 Budget (*October 14*)
- RethinkWaste Board Study Session: Review (Draft) 2026 Fiscal Year Budget + CIP Plan (*October 23*)

September – December 2025

- Member Agencies establish/issue Prop. 218 notices and approve their final 2026 solid waste rates

November 2025

- Approval of RethinkWaste's Final Fiscal Year 2026 Budget at the November 20 Board meeting

STAFF REPORT

To: RethinkWaste Board Members
From: John Mangini, Senior Finance Manager
Date: February 27, 2025 Board of Directors Meeting
Subject: Check Register Detail for November, December 2024 and January 2025

Recommendation

This is an informational item only and no action is required. This report was requested by the Board members.

Summary

The purpose of this report is to provide transparency to the Board and the public on the actual spending by RethinkWaste. All payments issued in November 2024 are listed on the attached (Attachment A) report for review.

Analysis

As of July 1, 2019, RethinkWaste entered into a contract with the City of Redwood City for accounting services including the issuing of all payments and deposit of all receipts. In accordance with the RethinkWaste and the City of Redwood City's policies, checks are normally issued every two weeks. All RethinkWaste invoices are approved for payment by the program manager and then by the Executive Director or Finance Manager. The total transactions for November 2024 summed \$1,822,875.42 and for December 2024 summed \$6,034,387.98, and for January 2025 summed \$7,304,581.10 as detailed in **Attachment A**.

If you have any questions on this, please contact Dolores Molina-Bucio or John Mangini.

Attachments:

Attachment A – November and December 2024 and January 2025 Check Register Detail

South Bayside Waste Management Authority

Check Detail

November 2024

DATE	NUM	NAME	MEMO/DESCRIPTION	ACCOUNT	TRANSACTION TYPE	AMOUNT
100010 Wells Fargo Bank						
11/06/2024		MODERN HR, INC.		100010 Wells Fargo Bank	Expense	-72,682.08
			PPE 11/02/2024	500000 Salaries - Admin		30,341.75
			PPE 11/02/2024	500100 Salaries - Recycling		36,058.67
			PPE 11/02/2024	500110 SB1383 Staff		4,557.69
			PPE 11/02/2024	501000 Benefits - Payroll Taxes		1,109.12
			PPE 11/02/2024	501005 Benefits - Workers Comp Ins		396.04
			PPE 11/02/2024	501010 Benefits - Retirement Employee		-5,814.40
			PPE 11/02/2024	501030 Benefits - CPE Fee		833.60
			PPE 11/02/2024	500150 Salaries - Car Allowance		3,600.00
			PPE 11/02/2024	500200 Salaries - Opt Out Medical		1,599.61
11/07/2024	12614	DOLORES MOLINA-BUCIO	OCT-24 EMPLOYEE EXPENSE REIMB	100010 Wells Fargo Bank	Check	-26.51
			OCT-24 OFFICE SUPPLIES EXPENSE REIMBURSEMENT	503030 Office Supplies		26.51
11/07/2024	12615	E-RECYCLING OF CALIFORNIA	LOAD DATE: 10/02/2024,10/16/2024,10/18/2024,10/21/2024,10/23/24,10/25/2024 390.001,143.012	100010 Wells Fargo Bank	Check	-1,230.26
			I2404483	400400 E-Recycling Revenue		-473.95
			I2404482	400400 E-Recycling Revenue		-535.16
			I2404484	400400 E-Recycling Revenue		-390.50
			I2404640	400400 E-Recycling Revenue		292.87
			I2404486	400400 E-Recycling Revenue		93.08
			I2404487	400400 E-Recycling Revenue		-216.60
11/07/2024	12616	E-RECYCLING OF CALIFORNIA	LOAD DATE: 10/19/2024 143.005	100010 Wells Fargo Bank	Check	-2,143.57
			I2402110	400400 E-Recycling Revenue		-2,143.57
11/07/2024	12617	SHRED WORKS INC	INV# 62917, 62919	100010 Wells Fargo Bank	Check	-1,722.00
			INV# 62917 SHRED EVENTS 10/19/2024 (TRUCK #1)	506030 Shred Event Svcs (pass thru)		861.00
			INV# 62919 SHRED EVENTS 10/19/2024 10/19/2024 (TRUCK #2)	506030 Shred Event Svcs (pass thru)		861.00
11/07/2024	12618	ULINE INC	INV# 18490630	100010 Wells Fargo Bank	Check	-700.65
			INV# 184690630 IN SCHOOL PROGRAMS	5060208 In-School Environmental Education		700.65
11/07/2024	12619	AT&T	Acct. #650-596-7146-704-9	100010 Wells Fargo Bank	Check	-2,456.65
			Shoreway Facility cost; monthly service Oct 13th thru Nov 12th 2024	507015 Shoreway Facility Cost		2,456.65
11/07/2024	12620	AT&T Internet	ACCT# *****4669	100010 Wells Fargo Bank	Check	-148.04
			AT&T INTERNET 10/25/2024-11/24/2024	507015 Shoreway Facility Cost		148.04
11/07/2024	12621	BEECHER ENGINEERING INC	INV# 1024-80	100010 Wells Fargo Bank	Check	-660.00
			PROFESSIONAL ELECTRICAL ENGINEERING SVCS 10/14/2024	505035 Project Assessments		660.00
11/07/2024	12622	DATA AXLE	INV# 10004260616	100010 Wells Fargo Bank	Check	-1,990.64
			CUSTT# 2499150			
			MFD OUTREACH SPECIALTY DATA BROKER ACQUISITION	5060203 Multi-Family Outreach		1,990.64
11/07/2024	12623	JASK DIGITAL PRINT AND COPY SOLUTIONS	INV# 0901-7468	100010 Wells Fargo Bank	Check	-43,005.01
			INV# 0901-7468 RETHINK WASTE SERVICE GUIDE MAILING	5060203 Multi-Family Outreach		19,431.03
			INV# 0901-7468 USPS POSTAGE	5060203 Multi-Family Outreach		8,616.56
			INV# 0901-7468 USPS POSTAGE	5060203 Multi-Family Outreach		7,200.57
			INV# 0901-7468 USPS POSTAGE	5060203 Multi-Family Outreach		7,756.85
11/07/2024	12624	SAN MATEO COUNTY TAX COLLECTOR	BILL# 2024-418504	100010 Wells Fargo Bank	Check	-712.50
			PARCEL 118-140-050			
			BILL# 2024-418504 FY24-25 PROPERTY TAX	507050 Sewer Fees (property tax)		712.50
11/07/2024	12625	SAN MATEO COUNTY TAX COLLECTOR	BILL# 2024-310202	100010 Wells Fargo Bank	Check	-30,853.09
			PARCEL 046-081-820			
			BILL# 2024-310202 FY24-25 PROPERTY TAX	507050 Sewer Fees (property tax)		30,853.09

South Bayside Waste Management Authority

Check Detail

November 2024

DATE	NUM	NAME	MEMO/DESCRIPTION	ACCOUNT	TRANSACTION TYPE	AMOUNT
				tax)		
11/07/2024	12626	INTELLI-TECH	INV# 390986 PO# 2024-02 INV# 390986 OCTOBER 2024	100010 Wells Fargo Bank	Check	-62,338.36
			INV# 390986: 10% RETENTION	6001001 Facilities Improvements (SF049) 200115 Retention Payable		69,264.85 6,926.49
11/07/2024	12627	WAXIE'S ENTERPRISES, INC.	Inv 82755384; 82832922 Cust #: 56037 Slim Jim Covers for Internal Commercial Containers	100010 Wells Fargo Bank	Check	-10,589.47
			Slim Jim Covers for Internal Commercial Containers	5060202 Commercial/MFD Containers 5060202 Commercial/MFD Containers		989.25 9,600.22
11/07/2024	12628	MANPREET CHANDOK	JUL - OCT 2024 EMPLOYEE EXPENSE REIMB JUL - OCT 2024 MILEAGE REIMBURSEMENT	100010 Wells Fargo Bank 503050 Mileage reimbursements	Check	-44.56 44.56
11/07/2024	12629	AAA BUSINESS SUPPLIES	INV# 2379593-1 207917 INV# 2379593-1	100010 Wells Fargo Bank 503030 Office Supplies	Check	-87.83 87.83
11/07/2024	12630	ARROW LIFT	INV# P-SI20306 SBWMA ADMIN OFFICE PHONE CONTRACT 10/21/2024-10/21/2025	100010 Wells Fargo Bank 503030 Office Supplies	Check	-300.00 300.00
11/07/2024	12631	CW SILICON VALLEY LLC	INV# 32051003217, 42051002043 INV# 32051003217 INV# 42051002043	100010 Wells Fargo Bank 503030 Office Supplies 503030 Office Supplies	Check	-2,325.33 2,092.00 233.33
11/07/2024	12632	CYNDI URMAN	OCTOBER 2024 EMPLOYEE EXPENSE REIMBURSEMENT OCTOBER 2024 EMPLOYEE EXPENSE REIMBURSEMENT	100010 Wells Fargo Bank 502010 Board Administration	Check	-47.97 47.97
11/07/2024	12633	LANALERT, INC.	Inv# 1941 NOVEMBER 2024	100010 Wells Fargo Bank 502020 IT Support	Check	-4,011.14 4,011.14
11/07/2024	12634	GELFAND PARTNERS ARCHITECTS	INV# 10 PROJ# 2321.00 PROFESSIONAL SERVICES SEPTEMBER 2024	100010 Wells Fargo Bank 503025 Tenant Improvements	Check	-2,184.00 2,184.00
11/07/2024	12635	KBA DOCUMENT SOLUTIONS, LLC	INV# 55Y1491045 ACCT# SB15 INV# 55Y1491045	100010 Wells Fargo Bank 503035 Office Equipment Costs	Check	-54.45 54.45
11/07/2024	12636	LOCKWORKS UNLIMITED	INV# I241024725, I241024728 INV# I241024725 INV# I241024728	100010 Wells Fargo Bank 503035 Office Equipment Costs 503035 Office Equipment Costs	Check	-4,138.36 7.11 4,131.25
11/07/2024	12637	LYNGSO GARDEN MATERIALS INC	RENT FOR NOVEMBER 2024 Lease of 8 Parking Spaces November 2024	100010 Wells Fargo Bank 507015 Shoreway Facility Cost	Check	-1,200.00 1,200.00
11/07/2024	12638	JOHN MANGINI	Mar-24- Sep-24 Cell Phone Employee Expense Reimbursement Cell Phone Employee Expense Reimbursement 03/07/2024-09/07/2024	100010 Wells Fargo Bank 503055 Cell Phones	Check	-315.00 315.00
11/07/2024	12639	UNIVOIP INC	INV# IN19420 ACCT# ****0063 November 2024	100010 Wells Fargo Bank 503020 Utilities & Phone	Check	-669.76 669.76
11/08/2024		CALIFORNIA DEPARTMENT OF TAX AND FEE ADMINISTRATION	PERIOD END DATE: 12/31/2023	100010 Wells Fargo Bank 507015 Shoreway Facility Cost	Expense	-434.48 434.48
11/12/2024	12640	FORSIGHT CREATIONS	INV# 24-C0040 Way-Finding and Design Services: PRC Signage	100010 Wells Fargo Bank 6001009 Facilities Improvements (SF072)	Check	-14,496.25 14,496.25
11/12/2024		JOHN HANCOCK USA	EE Contribution PPE 10/24/2024 ER Contribution PPE 10/24/2024	100010 Wells Fargo Bank 501010 Benefits - Retirement Employee 501015 Benefits - Retirement Employer	Expense	-16,163.20 7,506.03 8,657.17

South Bayside Waste Management Authority

Check Detail

November 2024

DATE	NUM	NAME	MEMO/DESCRIPTION	ACCOUNT	TRANSACTION TYPE	AMOUNT
11/12/2024		JOHN HANCOCK USA	EE Contribution PPE 10/10/2024	100010 Wells Fargo Bank 501010 Benefits - Retirement Employee	Expense	-16,716.14 8,324.07
			ER Contribution PPE 10/10/2024	501015 Benefits - Retirement Employer		8,392.07
11/12/2024		WELLS FARGO	October 2024 Client Analysis Service Charge	100010 Wells Fargo Bank 503005 Bank Fees & Services	Expense	-827.07 827.07
11/12/2024		STERLING HSA	November 2024 HSA	100010 Wells Fargo Bank	Expense	-1,217.06
			November 2024- Sterling HSA	501025 Benefits - Sterling HSA		1,217.06
11/14/2024	12642	JASK DIGITAL PRINT AND COPY SOLUTIONS	INV# 0901-7480	100010 Wells Fargo Bank	Check	-15,687.94
			INV# 0901-7480 0901-7480	5060204 Member Agency & Rate Payer Education		6,420.73
			INV# 0901-7480 0901-7480	5060204 Member Agency & Rate Payer Education		9,267.21
11/14/2024	12641	WELLS FARGO	Acct# **** * 1909	100010 Wells Fargo Bank	Check	-9,586.72
			Outstanding Balance as of: 10/28/2024			
			WF 10/28/2024	503060 Conferences & Meetings		506.45
			WF 10/28/2024	502009 SB1383 Program Expenses		1,079.88
			WF 10/28/2024	6001031 Underground Storage Tank Project		6,970.69
			WF 10/28/2024	503060 Conferences & Meetings		49.00
			WF 10/28/2024	5060206 Community Events		134.75
			WF 10/28/2024	5060206 Community Events		33.59
			WF 10/28/2024	5060206 Community Events		66.37
			WF 10/28/2024	502010 Board Administration		89.10
			WF 10/28/2024	503030 Office Supplies		87.90
			WF 10/28/2024	503025 Tenant Improvements		249.22
			WF 10/28/2024	503025 Tenant Improvements		319.77
11/15/2024		CITY OF SAN CARLOS	OCTOBER 2024 FRANCHISE FEE	100010 Wells Fargo Bank 507055 Franchise Fee to the City of San Carlos	Expense	-231,912.04 231,912.04
11/20/2024		MODERN HR, INC.	PPE 11/16/2024	100010 Wells Fargo Bank	Expense	-68,161.08
			PPE 11/16/2024	500000 Salaries - Admin		30,341.77
			PPE 11/16/2024	500100 Salaries - Recycling		36,697.58
			PPE 11/16/2024	500110 SB1383 Staff		4,557.69
			PPE 11/16/2024	501000 Benefits - Payroll Taxes		1,038.16
			PPE 11/16/2024	501005 Benefits - Workers Comp Ins		372.31
			PPE 11/16/2024	501010 Benefits - Retirement Employee		-5,680.03
			PPE 11/16/2024	501030 Benefits - CPE Fee		833.60
			PPE 11/16/2024	500150 Salaries - Car Allowance		
			PPE 11/16/2024	500200 Salaries - Opt Out Medical		
11/21/2024	12643	E-RECYCLING OF CALIFORNIA	LOAD DATE: 10/28/2024, 10/30/2024, 11/01/2024, 11/04/2024	100010 Wells Fargo Bank	Check	-321.87
			390.001			
			I2404488	400400 E-Recycling Revenue		-235.68
			I2404489	400400 E-Recycling Revenue		-91.83
			I2404490	400400 E-Recycling Revenue		-121.14
			I2405039	400400 E-Recycling Revenue		126.78
11/21/2024	12644	CLARA COADY	NOV-24 EMPLOYEE EXPENSE REIMB	100010 Wells Fargo Bank	Check	-43.80
			EMPLOYEE EXPENSE REIMB NOV-24	503030 Office Supplies		43.80
11/21/2024	12645	ROYAL COACH TOURS	Inv# 30627, 30628	100010 Wells Fargo Bank	Check	-1,050.00
			Project #: Charter 31742/61000			
			Project #: Charter 32877/63413			
			INV# 30627 Transportation Services October 2024	507035 Education Center Operations		525.00

South Bayside Waste Management Authority

Check Detail

November 2024

DATE	NUM	NAME	MEMO/DESCRIPTION	ACCOUNT	TRANSACTION TYPE	AMOUNT
			INV# 30628 Transportation Services October 2024	507035 Education Center Operations		525.00
11/21/2024	12646	WHISK CATERING	INV. # 000027 INV# 27 COMMUNITY EVENTS	100010 Wells Fargo Bank 5060206 Community Events	Check	-1,640.70 1,640.70
11/21/2024	12647	EAST BAY MUNICIPAL UTILITY DISTRICT	Inv# 8041017 Shoreway Environmental Ctr Permit Renewal February 2024 Shoreway Facility Cost- SOBA3002	100010 Wells Fargo Bank 507015 Shoreway Facility Cost 507015 Shoreway Facility Cost	Check	-498.40 350.00 148.40
11/21/2024	12648	SCAPES INC	Inv# 68322 Shoreway Facility Cost- October 2024	100010 Wells Fargo Bank 507015 Shoreway Facility Cost	Check	-375.00 375.00
11/21/2024	12649	WALSCHON FIRE PROTECTION INC	INV# 240296.2 Fire Protection Service: Quarterly Inspection	100010 Wells Fargo Bank 507015 Shoreway Facility Cost	Check	-1,360.00 1,360.00
11/21/2024	12650	ECO PROMOTIONAL PRODUCTS, INC.	INV# 31684 INV# 31684 CUSTOM IMPRINT EVENT GIVEAWAYS	100010 Wells Fargo Bank 5060001 Giveaways - Schools and events	Check	-2,154.00 2,154.00
11/21/2024	12651	Environmental and Energy Consulting	INV# 3509 OCTOBER 2024	100010 Wells Fargo Bank 504000 Legislative & Reg Advocacy	Check	-6,000.00 6,000.00
11/21/2024	12652	WILLARD DANIEL DECKER JR	INV# 3143 SHOREWAY PROJ ASSESSMENT: OCTOBER 2024	100010 Wells Fargo Bank 505035 Project Assessments	Check	-3,804.40 3,804.40
11/21/2024	12653	AARONSON DICKERSON COHN & LANZONE, APC	Inv# 2099 Inv# 2099	100010 Wells Fargo Bank 502005 Board Counsel	Check	-8,811.95 8,811.95
11/21/2024	12654	CITY OF SAN CARLOS	INV# 24121 Apr 2024 - Jun 2024 Library Utility & Janitorial Charges	100010 Wells Fargo Bank 503020 Utilities & Phone	Check	-5,163.55 5,163.55
11/21/2024	12655	KLAR INC	INV#1024 INSTALLATION OF 15% DUAL REFLECTIVE FILM (AVERY DENNISON DR OPTITUNE 15i) ON FRONT OFFICE DOORS AND WINDOWS	100010 Wells Fargo Bank 503025 Tenant Improvements	Check	-1,280.00 1,280.00
11/21/2024	12656	WELLS FARGO VENDOR FINANCIAL SERVICES LLC	INV# 5031969894 CONTRACT# 450-014222-000 10/29/2024-11/28/2024	100010 Wells Fargo Bank 503035 Office Equipment Costs	Check	-438.93 438.93
11/21/2024	12657	OTM FURNITURE INSTALLATIONS	INV# 543384-CO1 FURNITURE INSTALLATION SERVICES	100010 Wells Fargo Bank 6001030 New Office Buildout	Check	-424.00 424.00
11/21/2024	12658	PEN MEDIA	INV# 1430 Inv# 1430 Labor Install Services New Board Room Final Payment	100010 Wells Fargo Bank 503025 Tenant Improvements	Check	-7,750.00 7,750.00
11/21/2024	12659	COUNTY OF SAN MATEO AIRPORTS	TEMPORARY USE PERMIT 5411- DEC 2024 TEMPORARY USE PERMIT 5411- DEC 2024	100010 Wells Fargo Bank 6001031 Underground Storage Tank Project	Check	-14,762.30 14,762.30
11/21/2024	12660	UNIVOIP INC	INV# IN19420 ACCT# ****0063 December 2024	100010 Wells Fargo Bank 503020 Utilities & Phone	Check	-669.76 669.76
11/21/2024	12661	WHEELER PLAZA OWNERS' ASSOCIATION	Account# *****2076 1245 San Carlos Avenue Unit E HOA Dues December 2024	100010 Wells Fargo Bank 503010 Rent	Check	-313.10 313.10
11/21/2024	12662	TANNER PACIFIC INC	INV# 224-370, 224-392 TPI PROJ# 602401.13 UNDERGROUND STORAGE TANK REMOVAL SEPTEMBER 2024 UNDERGROUND STORAGE TANK REMOVAL OCTOBER 2024	100010 Wells Fargo Bank 6001031 Underground Storage Tank Project 6001031 Underground Storage Tank Project	Check	-28,535.00 10,677.50 17,857.50
11/21/2024	12663	JOE LA MARIANA	EMPLOYEE EXPENSE REIMB: SEPT-24-NOV-24 CELL PHONE REIMB: 08/23/2024-10/23/2024 CELL PHONE REIMB: 08/23/2024-10/23/2024	100010 Wells Fargo Bank 503055 Cell Phones	Check	-5,743.63 123.00

South Bayside Waste Management Authority

Check Detail

November 2024

DATE	NUM NAME	MEMO/DESCRIPTION	ACCOUNT	TRANSACTION TYPE	AMOUNT
		CONF & MEETINGS REIMB: SEPT-24	503060 Conferences & Meetings		146.25
		OFFICE SUPPLIES REIMB: SEPT-24 - NOV-24	503030 Office Supplies		360.48
		TENTANT IMPROV REIMB: NOV-24	503025 Tenant Improvements		5,113.90
11/25/2024	KAISER PERMANENTE	KAISER DECEMBER 2024	100010 Wells Fargo Bank	Expense	-2,248.67
			501020 Benefits - Medical		2,248.67
11/26/2024	ANTHEM BLUE CROSS	Group insurance - December 2024	100010 Wells Fargo Bank	Expense	-14,115.42
			501020 Benefits - Medical		14,115.42
11/27/2024	PRINCIPAL LIFE INSURANCE COMPANY	DECEMBER 2024	100010 Wells Fargo Bank	Expense	-2,073.06
			501035 Benefits - Guardian Life		2,073.06
11/27/2024	CIC		100010 Wells Fargo Bank	Expense	-
		23008.005-2024.09	6001031 Underground Storage Tank Project		1,083,564.76
		23008.005-2024.09	200115 Retention Payable		108,301.65
		23008.006-2024.10	6001031 Underground Storage Tank Project		5,415.08
		23008.006-2024.10	200115 Retention Payable		1,032,292.83
				Total:WellsFargo:	\$1,814,981.51
100015 Five Star Checking					
11/15/2024	FIVE STAR BANK		100015 Five Star Checking	Expense	-7,893.91
		11/2024 Interest Payment #12	509110 Interest Expense		6,568.38
		11/2024 Principal Payment #12	200770 Five Star Loan		-1,325.53
			12335670		
				Total: FiveStar:	\$7,893.91
				TOTAL	\$1,822,875.42

South Bayside Waste Management Authority
Check Detail
December 2024

Date	Num	Name	Memo/Description	Account	Transaction Type	Amount
100010 Wells Fargo Bank						
12/04/2024		MODERN HR, INC.		100010 Wells Fargo Bank	Expense	-74,945.34
			PPE 11/30/2024	500000 Salaries - Admin		30,341.77
			PPE 11/30/2024	500100 Salaries - Recycling		36,058.67
			PPE 11/30/2024	500110 SB1383 Staff		4,557.69
			PPE 11/30/2024	501000 Benefits - Payroll Taxes		2,243.08
			PPE 11/30/2024	501005 Benefits - Workers Comp Ins		396.04
			PPE 11/30/2024	501010 Benefits - Retirement Employee		-4,685.12
			PPE 11/30/2024	501030 Benefits - CPE Fee		833.60
			PPE 11/30/2024	500150 Salaries - Car Allowance		3,600.00
			PPE 11/30/2024	500200 Salaries - Opt Out Medical		1,599.61
			LOAD DATE: 11/06/2024, 11/08/2024, 11/11/2024, 11/13/2024, 11/15/2024			
12/05/2024	12664	E-RECYCLING OF CALIFORNIA	390.001	100010 Wells Fargo Bank	Check	-1,401.52
			I2405040	400400 E-Recycling Revenue		103.16
			I2405041	400400 E-Recycling Revenue		-190.04
			I2405113	400400 E-Recycling Revenue		-596.93
			I2405114	400400 E-Recycling Revenue		-299.69
			I2405115	400400 E-Recycling Revenue		-418.02
12/05/2024	12665	ECO PROMOTIONAL PRODUCTS, INC.	INV# 31751	100010 Wells Fargo Bank	Check	-762.98
			INV# 31751 CUSTOM KEYCHAINS	507035 Education Center Operations		762.98
12/05/2024	12666	REYNA OCEGUERA	NOV-24 EMPLOYEE EXPENSE REIMB	100010 Wells Fargo Bank	Check	-58.19
			NOV-24 EMPLOYEE EXPENSE REIMB: BOARD MEETING	502010 Board Administration		58.19
12/05/2024	12667	AT&T	Acct. #650-596-7146-704-9	100010 Wells Fargo Bank	Check	-2,457.70
			Shoreway Facility cost; monthly service Nov 13th thru Dec 12th 2024	507015 Shoreway Facility Cost		2,457.70
12/05/2024	12668	BROWNING FERRIS INDUSTRIES OF CA INC	Inv# 4278-100009235 Cust# 4-4278-1001002	100010 Wells Fargo Bank	Check	-414,801.77
			Disposal Newby October 2024	5070102 Disposal & Processing - NEWBY		414,801.77
12/05/2024	12669	BFI OF CALIFORNIA INC Ox Mtn Landfill - 4227	Inv. #4227-000069387 Cust##4-4227-0000552	100010 Wells Fargo Bank	Check	-984,137.22
			DISPOSAL OX MTN. - October 2024	5070101 Disposal & Processing - OX		984,137.22
12/05/2024	12670	RECOLOGY BLOSSOM VALLEY ORGANICS-N	Inv # 200049	100010 Wells Fargo Bank	Check	-318,882.37
			DISPOSAL-BVON - October 2024	5070103 Disposal & Processing - BVON		318,882.37
12/05/2024	12671	ZANKER ROAD RESOURCE MANAGEMENT LLC	INV# 920241313 & 1020241308	100010 Wells Fargo Bank	Check	-596,550.87
			Disposal Zanker September 2024	5070104 Disposal & Processing - ZANKER		289,591.44
			Disposal Zanker October 2024	5070104 Disposal & Processing - ZANKER		306,959.43
12/05/2024	12672	EARTH ISLAND INSTITUTE INC	INV# RW-MISC-2024-11	100010 Wells Fargo Bank	Check	-95.00
			JEDI LENS WORKSHOP	503065 Training		95.00

South Bayside Waste Management Authority
Check Detail
December 2024

Date	Num	Name	Memo/Description	Account	Transaction Type	Amount
12/05/2024	12673	REAGAN CHUNG	NOV-24 EMPLOYEE EXPENSE REIMBURSEMENT	100010 Wells Fargo Bank	Check	-48.80
			NOV-24 OFFICE SUPPLIES EXPENSE REIMBURSEMENT	503030 Office Supplies		48.80
12/05/2024	12674	COUNTY OF SAN MATEO - SUSTAINABILITY DEPARTMENT	INV# GISCCFY2425004	100010 Wells Fargo Bank	Check	-26,153.44
			RETHINK WASTE'S CONTRIBUTION TTO THE COMPOST IMPROVEMENT DIGITAL CAMPAIGN (1 OF 2)	502008 SB1383 Outreach & Education		13,076.72
			RETHINK WASTE'S CONTRIBUTION TTO THE COMPOST IMPROVEMENT DIGITAL CAMPAIGN (1 OF 2)	5060205 Residential Outreach Programs		6,538.36
			RETHINK WASTE'S CONTRIBUTION TTO THE COMPOST IMPROVEMENT DIGITAL CAMPAIGN (1 OF 2)	5060203 Multi-Family Outreach		6,538.36
12/05/2024	12675	INTELLI-TECH	INV# 391044 PO# 2024-02	100010 Wells Fargo Bank	Check	-53,077.23
			INV# 391044 OFFICE BUILDOUT PROJECT	6001030 New Office Buildout		58,974.70
			INV# 391044: 10% RETENTION	200115 Retention Payable		5,897.47
12/05/2024	12676	ARC CONSTRUCTION AND ELECTRIC LLC	INV# 1613	100010 Wells Fargo Bank	Check	-5,520.00
			INV# 1613 OFFICE IMPROVEMENTS	503025 Tenant Improvements		5,520.00
12/05/2024	12677	Comcast	Acct# 8155200330542640	100010 Wells Fargo Bank	Check	-940.21
			Utilities; services from Oct 22 to Nov 21 2024	503020 Utilities & Phone		564.67
			Utilities; services from Nov 22 to Dec 21 2024	503020 Utilities & Phone		375.54
12/05/2024	12678	KBA DOCUMENT SOLUTIONS, LLC	INV# 55Y1496789 ACCT# SB15	100010 Wells Fargo Bank	Check	-5.44
			INV# 55Y1496789	503035 Office Equipment Costs		5.44
12/05/2024	12679	PG&E	ACCT# 9220945109-2	100010 Wells Fargo Bank	Check	-754.51
			STATEMENT DATE: 11/15/2024 ACCT# 9220945109-2	503020 Utilities & Phone		754.51
12/05/2024	12680	COUNTY OF SAN MATEO ENVIRONMENTAL HEALTH	INV# 00122115	100010 Wells Fargo Bank	Check	-2,531.00
			INV# 00122115	507030 Shoreway Charges		2,531.00
12/05/2024	12681	PITNEY BOWES GLOBAL FINANCIAL SERVICES LLC	INV# 3106932183 ACCT# 0012232627	100010 Wells Fargo Bank	Check	-166.06
			INV# 3106932183: 12/20/2024-03/19/2025	503035 Office Equipment Costs		166.06
12/05/2024	12682	JASK DIGITAL PRINT AND COPY SOLUTIONS	INV# 0901-7500	100010 Wells Fargo Bank	Check	-30,973.02
			INV# 0901-7500	5060204 Member Agency & Rate Payer Education		9,960.54
			INV# 0901-7500	5060204 Member Agency & Rate Payer Education		21,012.48
12/05/2024	12683	FORSIGHT CREATIONS	INV# 24-C0053	100010 Wells Fargo Bank	Check	-30,000.00
			Way-Finding and Design Services: PRC Signage	6001009 Facilities Improvements (SF072)		30,000.00
12/05/2024	12684	AM PARTY RENTALS INC	INV# 1-587602 12/12/2024	100010 Wells Fargo Bank	Check	-478.20
			Winter Event 12/12/2024	5060206 Community Events		478.20
12/09/2024		STERLING HSA	December 2024 HSA	100010 Wells Fargo Bank	Expense	-1,217.04
			December 2024- Sterling HSA	501025 Benefits - Sterling HSA		1,217.04

South Bayside Waste Management Authority
Check Detail
December 2024

Date	Num	Name	Memo/Description	Account	Transaction Type	Amount
12/10/2024		JOHN HANCOCK USA		100010 Wells Fargo Bank	Expense	-13,849.94
			EE Contribution PPE 11/21/2024	501010 Benefits - Retirement Employee		5,680.03
			ER Contribution PPE 11/21/2024	501015 Benefits - Retirement Employer		8,169.91
12/10/2024		JOHN HANCOCK USA		100010 Wells Fargo Bank	Expense	-14,101.65
			EE Contribution PPE 11/07/2024	501010 Benefits - Retirement Employee		5,814.40
			ER Contribution PPE 11/07/2024	501015 Benefits - Retirement Employer		8,287.25
12/10/2024	2024-10	SOUTH BAYSIDE INDUSTRIES.		100010 Wells Fargo Bank	Expense	-2,973,477.19
	2024-10		2024-10	5070105 Disposal & Processing - OTHER		140,364.45
	2024-10		2024-10	5070105 Disposal & Processing - OTHER		-16,861.94
	2024-10		2024-10	6001001 Facilities Improvements (SF049)		10,880.00
	2024-10		2024-10	400350 Miscellaneous Revenue		2,323.15
	2024-10		2024-10	507025 Credit Card Charges		16,191.19
	2024-10		2024-10	507015 Shoreway Facility Cost		21,562.03
	2024-10		2024-10	6001001 Facilities Improvements (SF049)		23,936.78
	2024-10		2024-10	6001001 Facilities Improvements (SF049)		85,949.60
	2024-10		2024-10	6001001 Facilities Improvements (SF049)		29,565.86
	2024-10		2024-10	6001001 Facilities Improvements (SF049)		37,395.80
	2024-10		2024-10	507005 Operator Compensation SBR		2,626,816.57
12/11/2024	12685	WELLS FARGO	Acct# **** * 1909 Outstanding Balance as of: 11/27/2024	100010 Wells Fargo Bank	Check	-7,189.51
			WF 11/27/2024	503030 Office Supplies		10.82
			WF 11/27/2024	503030 Office Supplies		43.73
			WF 11/27/2024	5060208 In-School Environmental Education		97.12
			WF 11/27/2024	5060203 Multi-Family Outreach		329.94
			WF 11/27/2024	5060205 Residential Outreach Programs		329.94
			WF 11/27/2024	504005 Computer Purchase for Office		1,761.87
			WF 11/27/2024	504005 Computer Purchase for Office		1,853.19
			WF 11/27/2024	503025 Tenant Improvements		265.23
			WF 11/27/2024	502025 Website Support		150.00
			WF 11/27/2024	502025 Website Support		19.99
			WF 11/27/2024	5060206 Community Events		137.20
			WF 11/27/2024	507035 Education Center Operations		13.99
			WF 11/27/2024	507035 Education Center Operations		468.00
			WF 11/27/2024	5060206 Community Events		6.91
			WF 11/27/2024	503030 Office Supplies		71.02
			WF 11/27/2024	503060 Conferences & Meetings		54.99
			WF 11/27/2024	503060 Conferences & Meetings		49.00
			WF 11/27/2024	5060206 Community Events		147.56
			WF 11/27/2024	503030 Office Supplies		18.37
			WF 11/27/2024	503025 Tenant Improvements		323.22
			WF 11/27/2024	5060206 Community Events		215.00

South Bayside Waste Management Authority
Check Detail
December 2024

Date	Num	Name	Memo/Description	Account	Transaction Type	Amount
			WF 11/27/2024	503030 Office Supplies		116.87
			WF 11/27/2024	503015 Printing & Postage		33.50
			WF 11/27/2024	503030 Office Supplies		100.00
			WF 11/27/2024	502010 Board Administration		46.59
			WF 11/27/2024	503025 Tenant Improvements		303.41
			WF 11/27/2024	502025 Website Support		63.97
			WF 11/27/2024	503005 Bank Fees & Services		39.00
			WF 11/27/2024	503005 Bank Fees & Services		119.08
12/11/2024		WELLS FARGO		100010 Wells Fargo Bank	Expense	-919.19
			November 2024 Client Analysis Service Charge	503005 Bank Fees & Services		919.19
12/12/2024	12686	ARACELI HURTADO	Inv# 1572	100010 Wells Fargo Bank	Check	-11,022.50
			Office Improvements	507035 Education Center Operations		11,022.50
12/17/2024	12687	CLARA COADY	NOV-24 EMPLOYEE EXPENSE REIMB	100010 Wells Fargo Bank	Check	-123.63
			EMPLOYEE EXPENSE REIMB NOV-24	507035 Education Center Operations		123.63
12/17/2024	12688	CLASSIC GRAPHICS	Inv# 50450, 50451	100010 Wells Fargo Bank	Check	-1,512.78
			Inv# 50450 Decals for Poster Contest	507035 Education Center Operations		756.39
			Inv# 50451 Decals for Poster Contest	507035 Education Center Operations		756.39
12/17/2024	12689	ULINE INC	INV# 186384235	100010 Wells Fargo Bank	Check	-790.08
			INV# 186384235 IN SCHOOL PROGRAMS	5060208 In-School Environmental Education		790.08
12/17/2024	12690	AT&T Internet	ACCT# 317554669	100010 Wells Fargo Bank	Check	-148.04
			AT&T INTERNET 11/25/2024-12/24/2024	507015 Shoreway Facility Cost		148.04
12/17/2024	12691	SCAPES INC	Inv# 68374	100010 Wells Fargo Bank	Check	-375.00
			Shoreway Facility Cost- November 2024	507015 Shoreway Facility Cost		375.00
12/17/2024	12692	MRF DESIGNS LLC	INV#003 & 004	100010 Wells Fargo Bank	Check	-8,100.00
			ORGANICS TO ENERGY PROCESSING SYSTEM ASSESSMENT OCTOBER 2024	6001001 Facilities Improvements (SF049)		1,100.00
			ORGANICS TO ENERGY PROCESSING SYSTEM ASSESSMENT NOVEMBER 2024	6001001 Facilities Improvements (SF049)		7,000.00
12/17/2024	12693	OMNIS RISK INSURANCE SOLUTIONS	POLICY: C4LPY052438CYBER2024	100010 Wells Fargo Bank	Check	-22,387.27
			ARCH SPECIALTY CYBER POLICY 12/09/2024-12/09/2025	507020 Insurance Shoreway		22,387.27
12/17/2024	12694	AMS SYSTEMS	INV# 62681	100010 Wells Fargo Bank	Check	-1,121.09
			INV# 62681 CUSTOM PRINTING: POSTCARD	5060203 Multi-Family Outreach		1,121.09
12/17/2024	12695	BEN FREDIA CONSULTING	Inv# 0005247, 0005290	100010 Wells Fargo Bank	Check	-1,994.00
			Maintenance & Hosting: November 2024	502025 Website Support		997.00
			Maintenance & Hosting: December 2024	502025 Website Support		997.00
12/17/2024	12696	Environmental and Energy Consulting	INV# 3538	100010 Wells Fargo Bank	Check	-6,000.00
			NOVEMBER 2024	504000 Legislative & Reg Advocacy		6,000.00

South Bayside Waste Management Authority
Check Detail
December 2024

Date	Num	Name	Memo/Description	Account	Transaction Type	Amount
12/17/2024	12697	STUDIO EM GRAPHIC DESIGN	INV# 19297, 19296	100010 Wells Fargo Bank	Check	-3,382.88
			INV# 19297: LONG RANGE PLAN 2025	506005 Long Range Plan		3,000.94
			INV# 19296: HOLIDAY SCHEDULE POSTCARD 2024	5060204 Member Agency & Rate Payer Education		381.94
12/17/2024	12698	ECO PROMOTIONAL PRODUCTS, INC.	INV# 31819	100010 Wells Fargo Bank	Check	-4,551.30
			INV# 31819 CUSTOM PRODUCE BAGS	5060001 Giveaways - Schools and events		4,551.30
12/17/2024	12699	E-RECYCLING OF CALIFORNIA	LOAD DATE: 11/07/2024, 11/18/2024, 11/20/2024, 11/22/2024, 11/25/2024, 11/27/2024, 11/29/2024, 12/02/2024			
			390.001, 143.012	100010 Wells Fargo Bank	Check	-2,379.53
			I2405119	400400 E-Recycling Revenue		-564.60
			I2405116	400400 E-Recycling Revenue		-109.73
			I2405117	400400 E-Recycling Revenue		-394.37
			I2405118	400400 E-Recycling Revenue		-252.87
			I2405256	400400 E-Recycling Revenue		-73.15
			I2405120	400400 E-Recycling Revenue		-522.98
			I2405121	400400 E-Recycling Revenue		-309.50
I2405484	400400 E-Recycling Revenue		-152.33			
12/17/2024	12700	AAA BUSINESS SUPPLIES	INV# 2393360-0 207917	100010 Wells Fargo Bank	Check	-436.10
			INV# 2393360-0	503030 Office Supplies		436.10
12/17/2024	12701	AARONSON DICKERSON COHN & LANZONE, APC	Inv# 2110	100010 Wells Fargo Bank	Check	-8,102.83
			Inv# 2110	502005 Board Counsel		8,102.83
12/17/2024	12702	COMMON GOAL CONSULTING GROUP, INC	INV# 3, 4, 5	100010 Wells Fargo Bank	Check	-1,612.50
			INV# 3	505005 Facility Improvement Oversight		637.50
			INV#4	503025 Tenant Improvements		750.00
			INV#5	503025 Tenant Improvements		225.00
12/17/2024	12703	CONSTRUCTION TESTING SERVICES INC	INV# 20267-5	100010 Wells Fargo Bank	Check	-539.70
			INV# 20267-5 SEPTEMBER 2024	6001030 New Office Buildout		539.70
12/17/2024	12704	LANALERT, INC.	Inv# 1949	100010 Wells Fargo Bank	Check	-4,011.14
			DECEMBER 2024	502020 IT Support		4,011.14
12/17/2024	12705	LOCKWORKS UNLIMITED	INV# I241205481	100010 Wells Fargo Bank	Check	-701.19
			INV# I241205481	503035 Office Equipment Costs		701.19
12/17/2024	12706	LYNGSO GARDEN MATERIALS INC	RENT FOR DECEMBER 2024	100010 Wells Fargo Bank	Check	-1,200.00
			Lease of 8 Parking Spaces December 2024	507015 Shoreway Facility Cost		1,200.00
12/17/2024	12707	PEN MEDIA	INV# 1446	100010 Wells Fargo Bank	Check	-2,115.00
			Inv# 1446 Meeting Coverage Sept/Oct/Nov 2024	502010 Board Administration		2,115.00
12/17/2024	12708	S.R. ROSE ENGINEERING INC	INV# RTW-101	100010 Wells Fargo Bank	Check	-6,957.87
			INV# RTW-101	505005 Facility Improvement Oversight		6,957.87
12/17/2024	12709	SERVICE PRESS, INC.	Inv# 65334	100010 Wells Fargo Bank	Check	-430.35
			Office Supplies	503030 Office Supplies		430.35

South Bayside Waste Management Authority
Check Detail
December 2024

Date	Num	Name	Memo/Description	Account	Transaction Type	Amount
12/17/2024	12710	UNIVOIP INC	INV# IN19853 ACCT# 11110063 December 2024	100010 Wells Fargo Bank 503020 Utilities & Phone	Check	-668.27 668.27
12/17/2024	12711	WHEELER PLAZA OWNERS' ASSOCIATION	Account# 716442076 1245 San Carlos Avenue Unit E HOA Dues January 2024	100010 Wells Fargo Bank 503010 Rent	Check	-313.10 313.10
12/18/2024		MODERN HR, INC.	PPE 12/14/2024 PPE 12/14/2024 PPE 12/14/2024 PPE 12/14/2024 PPE 12/14/2024 PPE 12/14/2024 PPE 12/14/2024 PPE 12/14/2024 PPE 12/14/2024 PPE 12/14/2024	100010 Wells Fargo Bank 500000 Salaries - Admin 500100 Salaries - Recycling 500110 SB1383 Staff 501000 Benefits - Payroll Taxes 501005 Benefits - Workers Comp Ins 501010 Benefits - Retirement Employee 501030 Benefits - CPE Fee 500150 Salaries - Car Allowance 500200 Salaries - Opt Out Medical	Expense	-69,201.06 30,341.77 36,507.33 4,557.69 1,035.40 371.33 -4,498.16 885.70
12/20/2024		CITY OF SAN CARLOS	NOVEMBER 2024 FRANCHISE FEE	100010 Wells Fargo Bank 507055 Franchise Fee to the City of San Carlos	Expense	-220,405.24 220,405.24
12/24/2024		KAISER PERMANENTE	KAISER JANUARY 2025	100010 Wells Fargo Bank 501020 Benefits - Medical	Expense	-2,248.67 2,248.67
12/27/2024		ANTHEM BLUE CROSS	Group insurance - January 2025	100010 Wells Fargo Bank 501020 Benefits - Medical	Expense	-14,115.42 14,115.42
12/27/2024		PRINCIPAL LIFE INSURANCE COMPANY	JANUARY 2025	100010 Wells Fargo Bank 501035 Benefits - Guardian Life	Expense	-2,395.48 2,395.48
12/31/2024		MODERN HR, INC.	PPE 12/28/2024 PPE 12/28/2024 PPE 12/28/2024 PPE 12/28/2024 PPE 12/28/2024 PPE 12/28/2024 PPE 12/28/2024 PPE 12/28/2024 PPE 12/28/2024 PPE 12/28/2024	100010 Wells Fargo Bank 500000 Salaries - Admin 500100 Salaries - Recycling 500110 SB1383 Staff 501000 Benefits - Payroll Taxes 501005 Benefits - Workers Comp Ins 501010 Benefits - Retirement Employee 501030 Benefits - CPE Fee 500150 Salaries - Car Allowance 500200 Salaries - Opt Out Medical	Expense	-71,656.66 30,341.55 36,370.15 4,557.69 3,039.55 397.66 -9,135.25 885.70 3,600.00 1,599.61
				TOTAL WELLS FARGO BANK		<u>-6,026,494.07</u>
100015 FIVE STAR CHECKING						
12/15/2024		FIVE STAR BANK	12/2024 INTEREST PAYMENT 12/2024 PRINCIPAL PAYMENT		Expense	-7,893.91 6,787.15 1,106.76

South Bayside Waste Management Authority
Check Detail
 December 2024

Date	Num	Name	Memo/Description	Account	Transaction Type	Amount
					TOTAL FIVE STAR CHECKING	-7,893.91
						-6,034,387.98

**SOUTH BAYSIDE WASTE MANAGEMENT AUTHORITY
CHECK DETAIL REPORT
JANUARY 2025**

DATE	NUM	NAME	MEMO/DESCRIPTION	ACCOUNT	TRANSACTION TYPE	AMOUNT
100015 FIVE STAR CHECKING						
1/15/2025	ACH	FIVE STAR BANK	--	100015 FIVE STAR CHECKING	EXPENSE	(7,893.91)
1/15/2025	ACH	FIVE STAR BANK	01/2025 INTEREST PAYMENT	509110 INTEREST EXPENSE	EXPENSE	6,787.15
1/15/2025	ACH	FIVE STAR BANK	01/2025 PRINCIPAL PAYMENT	200770 FIVE STAR LOAN 12335670	EXPENSE	1,106.76
TOTAL 100015 FIVE STAR CHECKING						(7,893.91)
100010 WELLS FARGO BANK						
1/2/2025	12723	CW SILICON VALLEY LLC	INV# 32051003375JANUARY 2025	100010 Wells Fargo Bank	Check	(2,092.00)
1/2/2025	12723	CW SILICON VALLEY LLC	INV# 32051003375 JAN 2025	503020 Utilities & Phone	Check	2,092.00
1/2/2025	12712	AAA BUSINESS SUPPLIES	INV# 2396599-0, 2397056-0, 2393360-1, 2396599.1 ACCT# 207917	100010 Wells Fargo Bank	Bill Payment (Check)	(333.31)
1/2/2025	12712	AAA BUSINESS SUPPLIES	INV# 2396599-0, 2397056-0, 2393360-1, 2396599.1 ACCT# 207917	503030 503030 Office Supplies	Bill Payment (Check)	99.75
1/2/2025	12712	AAA BUSINESS SUPPLIES	INV# 2396599-0, 2397056-0, 2393360-1, 2396599.1 ACCT# 207917	503030 503030 Office Supplies	Bill Payment (Check)	105.26
1/2/2025	12712	AAA BUSINESS SUPPLIES	INV# 2396599-0, 2397056-0, 2393360-1, 2396599.1 ACCT# 207917	503030 503030 Office Supplies	Bill Payment (Check)	87.83
1/2/2025	12712	AAA BUSINESS SUPPLIES	INV# 2396599-0, 2397056-0, 2393360-1, 2396599.1 ACCT# 207917	503030 503030 Office Supplies	Bill Payment (Check)	40.47
1/2/2025	12713	AARONSON DICKERSON COHN & LANZONE, APC	INV# 2124	100010 Wells Fargo Bank	Bill Payment (Check)	(4,367.69)
1/2/2025	12713	AARONSON DICKERSON COHN & LANZONE, APC	INV# 2124	502005 502005 Board Counsel	Bill Payment (Check)	4,367.69
1/2/2025	12714	AT&T	ACCT# 65059671467049	100010 Wells Fargo Bank	Bill Payment (Check)	(2,396.98)
1/2/2025	12714	AT&T	ACCT# 65059671467049	507015 507015 Shoreway Facility Cost	Bill Payment (Check)	2,396.98
1/2/2025	12715	AT&T Internet	ACCT# 317554669	100010 Wells Fargo Bank	Bill Payment (Check)	(148.04)
1/2/2025	12715	AT&T Internet	ACCT# 317554669	507015 507015 Shoreway Facility Cost	Bill Payment (Check)	148.04
1/2/2025	12716	BFI OF CALIFORNIA INC Ox Mtn Landfill - 4227	Inv# 4227000069622 Cust# 4-4227-0000552	100010 Wells Fargo Bank	Bill Payment (Check)	(961,880.19)
1/2/2025	12716	BFI OF CALIFORNIA INC Ox Mtn Landfill - 4227	Inv# 4227000069622 Cust# 4-4227-0000552	5070101 5070101 Disposal & Processing - I	Bill Payment (Check)	961,880.19
1/2/2025	12717	BROWNING FERRIS INDUSTRIES OF CA INC	Inv# 4278100009280 Cust# 4-4278-1001002	100010 Wells Fargo Bank	Bill Payment (Check)	(356,590.08)
1/2/2025	12717	BROWNING FERRIS INDUSTRIES OF CA INC	Inv# 4278100009280 Cust# 4-4278-1001002	5070102 5070102 Disposal & Processing - I	Bill Payment (Check)	356,590.08
1/2/2025	12718	CAROLINE PIETRZYK	Sep 2024 - Dec 2024 Winter Employee Expense Reimbursement	100010 Wells Fargo Bank	Bill Payment (Check)	(90.64)
1/2/2025	12718	CAROLINE PIETRZYK	Sep 2024 - Dec 2024 Winter Employee Expense Reimbursement	5060206 5060206 Community Events	Bill Payment (Check)	18.00
1/2/2025	12718	CAROLINE PIETRZYK	Sep 2024 - Dec 2024 Winter Employee Expense Reimbursement	503030 503030 Office Supplies	Bill Payment (Check)	4.57
1/2/2025	12718	CAROLINE PIETRZYK	Sep 2024 - Dec 2024 Winter Employee Expense Reimbursement	503050 503050 Mileage reimbursements	Bill Payment (Check)	68.07
1/2/2025	12719	CIC	INV# 7 NOVEMBER 2024	100010 Wells Fargo Bank	Bill Payment (Check)	(354,708.15)
1/2/2025	12719	CIC	INV# 7 NOVEMBER 2024	6001031 6001031 Underground Storage Ta	Bill Payment (Check)	373,377.00
1/2/2025	12719	CIC	INV# 7 NOVEMBER 2024	200115 200115 Retention Payable	Bill Payment (Check)	(18,668.85)
1/2/2025	12720	CITY OF SAN CARLOS	Inv# 23792	100010 Wells Fargo Bank	Bill Payment (Check)	(5,618.00)
1/2/2025	12720	CITY OF SAN CARLOS	Inv# 23792	503010 503010 Rent	Bill Payment (Check)	5,618.00
1/2/2025	12721	CLARA COADY	DEC-24 EMPLOYEE EXPENSE REIMBURSEMENT	100010 Wells Fargo Bank	Bill Payment (Check)	(52.85)
1/2/2025	12721	CLARA COADY	DEC-24 EMPLOYEE EXPENSE REIMBURSEMENT	5060206 5060206 Community Events	Bill Payment (Check)	28.85
1/2/2025	12721	CLARA COADY	DEC-24 EMPLOYEE EXPENSE REIMBURSEMENT	503030 503030 Office Supplies	Bill Payment (Check)	24.00
1/2/2025	12722	Comcast	12/22/2024-01/21/2025 ACCT# 8155200330447972	100010 Wells Fargo Bank	Bill Payment (Check)	(365.54)
1/2/2025	12722	Comcast	12/22/2024-01/21/2025	503020 503020 Utilities & Phone	Bill Payment (Check)	365.54
1/2/2025	12725	FOUNDRY CONSTRUCTION INC	INV#9	100010 Wells Fargo Bank	Bill Payment (Check)	(323,458.54)
1/2/2025	12725	FOUNDRY CONSTRUCTION INC	INV#9	6001030 6001030 New Office Buildout	Bill Payment (Check)	340,482.54
1/2/2025	12725	FOUNDRY CONSTRUCTION INC	INV#9	200115 200115 Retention Payable	Bill Payment (Check)	(17,024.00)
1/2/2025	12726	GIGANTIC IDEA STUDIO	INV# 4356	100010 Wells Fargo Bank	Bill Payment (Check)	(3,920.75)
1/2/2025	12726	GIGANTIC IDEA STUDIO	INV# 4356	5060203 Mi Accounts Payable (A/P)	Bill Payment (Check)	489.38
1/2/2025	12726	GIGANTIC IDEA STUDIO	INV# 4356	5060205 Residential Outreach Programs	Bill Payment (Check)	489.37
1/2/2025	12726	GIGANTIC IDEA STUDIO	INV# 4356	506025 Curbside Battery Outreach	Bill Payment (Check)	2,942.00
1/2/2025	12727	INTELLI-TECH	INV# 391134	100010 Wells Fargo Bank	Bill Payment (Check)	(11,239.47)
1/2/2025	12727	INTELLI-TECH	INV# 391134	6001030 6001030 New Office Buildout	Bill Payment (Check)	12,488.30
1/2/2025	12727	INTELLI-TECH	INV# 391134	200115 200115 Retention Payable	Bill Payment (Check)	(1,248.83)
1/2/2025	12728	JULIA AU	OCT 2024 - DEC 2024 EMPLOYEE EXPENSE REIMBURSEMENT	100010 Wells Fargo Bank	Bill Payment (Check)	(72.44)
1/2/2025	12728	JULIA AU	OCT 2024 - DEC 2024 EMPLOYEE EXPENSE REIMBURSEMENT	502010 502010 Board Administration	Bill Payment (Check)	8.78
1/2/2025	12728	JULIA AU	OCT 2024 - DEC 2024 EMPLOYEE EXPENSE REIMBURSEMENT	503060 503060 Conferences & Meetings	Bill Payment (Check)	29.00
1/2/2025	12728	JULIA AU	OCT 2024 - DEC 2024 EMPLOYEE EXPENSE REIMBURSEMENT	503030 503030 Office Supplies	Bill Payment (Check)	34.66
1/2/2025	12729	LOCKWORKS UNLIMITED	Inv# 1241224816	100010 Wells Fargo Bank	Bill Payment (Check)	(6,229.50)
1/2/2025	12729	LOCKWORKS UNLIMITED	Inv# 1241224816	503025 503025 Tenant Improvements	Bill Payment (Check)	6,229.50
1/2/2025	12730	MANPREET CHANDOK	November - December 2024 Employee Expense Reimbursement	100010 Wells Fargo Bank	Bill Payment (Check)	(202.88)
1/2/2025	12730	MANPREET CHANDOK	November - December 2024 Employee Expense Reimbursement	503050 Mik Accounts Payable (A/P)	Bill Payment (Check)	15.41
1/2/2025	12730	MANPREET CHANDOK	November - December 2024 Employee Expense Reimbursement	5060206 Community Events	Bill Payment (Check)	187.47
1/2/2025	12731	MEGHAN PLETSCHE	NOV-24 EDU CENTER OPS EXPENSE REIMBURSEMENT	100010 Wells Fargo Bank	Bill Payment (Check)	(100.00)
1/2/2025	12731	MEGHAN PLETSCHE	NOV-24 EDU CENTER OPS EXPENSE REIMBURSEMENT	507035 507035 Education Center Operatic	Bill Payment (Check)	100.00
1/2/2025	12732	PG&E	NOV-24 EDU CENTER OPS EXPENSE REIMBURSEMENT	100010 Wells Fargo Bank	Bill Payment (Check)	(980.23)
1/2/2025	12732	PG&E	NOV-24 EDU CENTER OPS EXPENSE REIMBURSEMENT	503020 503020 Utilities & Phone	Bill Payment (Check)	980.23
1/2/2025	12733	RECOLOGY BLOSSOM VALLEY ORGANICS-N	5557Inv# 2000050: Disposal - BVON November 2024 Inv# 200044: Disposal - BVON May 2024	100010 Wells Fargo Bank	Bill Payment (Check)	(330,419.31)
1/2/2025	12733	RECOLOGY BLOSSOM VALLEY ORGANICS-N	5557Inv# 2000050: Disposal - BVON November 2024 Inv# 200044: Disposal - BVON May 2024	5070103 5070103 Disposal & Processing - I	Bill Payment (Check)	330,035.99
1/2/2025	12733	RECOLOGY BLOSSOM VALLEY ORGANICS-N	5557Inv# 2000050: Disposal - BVON November 2024 Inv# 200044: Disposal - BVON May 2024	5070103 5070103 Disposal & Processing - I	Bill Payment (Check)	383.32
1/2/2025	12734	RECOLOGY SAN MATEO COUNTY	PRJ SBWMA 0201: INV# 2024.115, PRJ SBWMA 0202: INV# 2024.116, PRJ SBWMA 0203: INV# 2024.117, INV# 10/31/2024: FUEL CREDIT OCT 2024, INV# 09/30/2024: FUEL CREDIT SEPT 2024	100010 Wells Fargo Bank	Bill Payment (Check)	(78,729.36)
1/2/2025	12734	RECOLOGY SAN MATEO COUNTY	PRJ SBWMA 0201: INV# 2024.115, PRJ SBWMA 0202: INV# 2024.116, PRJ SBWMA 0203: INV# 2024.117, INV# 10/31/2024: FUEL CREDIT OCT 2024, INV# 09/30/2024: FUEL CREDIT SEPT 2024	507015 507015 Shoreway Facility Cost	Bill Payment (Check)	512.00
1/2/2025	12734	RECOLOGY SAN MATEO COUNTY	PRJ SBWMA 0201: INV# 2024.115, PRJ SBWMA 0202: INV# 2024.116, PRJ SBWMA 0203: INV# 2024.117, INV# 10/31/2024: FUEL CREDIT OCT 2024, INV# 09/30/2024: FUEL CREDIT SEPT 2024	507015 507015 Shoreway Facility Cost	Bill Payment (Check)	29,055.58

**SOUTH BAYSIDE WASTE MANAGEMENT AUTHORITY
CHECK DETAIL REPORT
JANUARY 2025**

DATE	NUM	NAME	MEMO/DESCRIPTION	ACCOUNT	TRANSACTION TYPE	AMOUNT
1/2/2025	12734	RECOLOGY SAN MATEO COUNTY	PRJ SBWMA 0201: INV# 2024.115, PRJ SBWMA 0202: INV# 2024.116, PRJ SBWMA 0203: INV# 2024.117, INV# 10/31/2024: FUEL CREDIT OCT 2024, INV# 09/30/2024: FUEL CREDIT SEPT 2024	507015 507015 Shoreway Facility Cost	Bill Payment (Check)	2,784.00
1/2/2025	12734	RECOLOGY SAN MATEO COUNTY	PRJ SBWMA 0201: INV# 2024.115, PRJ SBWMA 0202: INV# 2024.116, PRJ SBWMA 0203: INV# 2024.117, INV# 10/31/2024: FUEL CREDIT OCT 2024, INV# 09/30/2024: FUEL CREDIT SEPT 2024	6001031 6001031 Underground Storage Ta	Bill Payment (Check)	37,877.90
1/2/2025	12734	RECOLOGY SAN MATEO COUNTY	PRJ SBWMA 0201: INV# 2024.115, PRJ SBWMA 0202: INV# 2024.116, PRJ SBWMA 0203: INV# 2024.117, INV# 10/31/2024: FUEL CREDIT OCT 2024, INV# 09/30/2024: FUEL CREDIT SEPT 2024	6001031 6001031 Underground Storage Ta	Bill Payment (Check)	8,499.88
1/2/2025	12735	ROYAL COACH TOURS	INV# 30323 CHARTER: 32935/63504	100010 Wells Fargo Bank	Bill Payment (Check)	(525.00)
1/2/2025	12735	ROYAL COACH TOURS	INV# 30323 CHARTER: 32935/63505	507035 507035 Education Center Operatic	Bill Payment (Check)	525.00
1/2/2025	12736	WELLS FARGO VENDOR FINANCIAL SERVICES LLC	INV# 503235278 CUST# 105595540	100010 Wells Fargo Bank	Bill Payment (Check)	(438.93)
1/2/2025	12736	WELLS FARGO VENDOR FINANCIAL SERVICES LLC	INV# 503235278 CUST# 105595540	503035 503035 Office Equipment Costs	Bill Payment (Check)	438.93
1/2/2025	12737	ZANKER ROAD RESOURCE MANAGEMENT LLC	Inv# 1120241304	100010 Wells Fargo Bank	Bill Payment (Check)	(232,833.73)
1/2/2025	12737	ZANKER ROAD RESOURCE MANAGEMENT LLC	Inv# 1120241304 LOAD DATE 11/25/24,12/04/24,12/06/24,12/09/24,12/11/24,12/13/24,12/16/24,12/18/24	5070104 5070104 Disposal & Processing -	Bill Payment (Check)	232,833.73
1/2/2025	12724	E-RECYCLING OF CALIFORNIA	ACCT# 143.013, 390.001 LOAD DATE 11/25/24,12/04/24,12/06/24,12/09/24,12/11/24,12/13/24,12/16/24,12/18/24	100010 Wells Fargo Bank	Bill Payment (Check)	(1,252.19)
1/2/2025	12724	E-RECYCLING OF CALIFORNIA	ACCT# 143.013, 390.001 LOAD DATE 11/25/24,12/04/24,12/06/24,12/09/24,12/11/24,12/13/24,12/16/24,12/18/24	400400 400400 E-Recycling Revenue	Bill Payment (Check)	499.57
1/2/2025	12724	E-RECYCLING OF CALIFORNIA	ACCT# 143.013, 390.001 LOAD DATE 11/25/24,12/04/24,12/06/24,12/09/24,12/11/24,12/13/24,12/16/24,12/18/24	400400 400400 E-Recycling Revenue	Bill Payment (Check)	179.68
1/2/2025	12724	E-RECYCLING OF CALIFORNIA	ACCT# 143.013, 390.001 LOAD DATE 11/25/24,12/04/24,12/06/24,12/09/24,12/11/24,12/13/24,12/16/24,12/18/24	400400 400400 E-Recycling Revenue	Bill Payment (Check)	(126.76)
1/2/2025	12724	E-RECYCLING OF CALIFORNIA	ACCT# 143.013, 390.001 LOAD DATE 11/25/24,12/04/24,12/06/24,12/09/24,12/11/24,12/13/24,12/16/24,12/18/24	400400 400400 E-Recycling Revenue	Bill Payment (Check)	(203.14)
1/2/2025	12724	E-RECYCLING OF CALIFORNIA	ACCT# 143.013, 390.001 LOAD DATE 11/25/24,12/04/24,12/06/24,12/09/24,12/11/24,12/13/24,12/16/24,12/18/24	400400 400400 E-Recycling Revenue	Bill Payment (Check)	309.84
1/2/2025	12724	E-RECYCLING OF CALIFORNIA	ACCT# 143.013, 390.001 LOAD DATE 11/25/24,12/04/24,12/06/24,12/09/24,12/11/24,12/13/24,12/16/24,12/18/24	400400 400400 E-Recycling Revenue	Bill Payment (Check)	212.83
1/2/2025	12724	E-RECYCLING OF CALIFORNIA	ACCT# 143.013, 390.001 LOAD DATE 11/25/24,12/04/24,12/06/24,12/09/24,12/11/24,12/13/24,12/16/24,12/18/24	400400 400400 E-Recycling Revenue	Bill Payment (Check)	649.74
1/2/2025	12724	E-RECYCLING OF CALIFORNIA	ACCT# 143.013, 390.001 LOAD DATE 11/25/24,12/04/24,12/06/24,12/09/24,12/11/24,12/13/24,12/16/24,12/18/24	400400 400400 E-Recycling Revenue	Bill Payment (Check)	(269.57)
1/13/2025	12738	INTERIOR PLANT DESIGN	Voided - INV# 250100144	100010 Wells Fargo Bank	Check	-
1/13/2025	12738	INTERIOR PLANT DESIGN	PLANT DESIGN (FIRST HALF)	503025 Tenant Improvements	Check	-
1/13/2025	12739	INTERIOR PLANT DESIGN	INV# 250100144	100010 Wells Fargo Bank	Check	(5,272.64)
1/13/2025	12739	INTERIOR PLANT DESIGN	PLANT DESIGN (FIRST HALF)	503025 Tenant Improvements	Check	5,272.64
1/13/2025	ACH	WELLS FARGO		100010 Wells Fargo Bank	Expense	(933.27)
1/13/2025	ACH	WELLS FARGO	December 2024 Client Analysis Service Charge	503005 Bank Fees & Services	Expense	933.27
1/15/2025	WIRE	MODERN HR, INC.		100010 Wells Fargo Bank	Expense	(66,335.76)
1/15/2025	WIRE	MODERN HR, INC.	PPE 01/11/2025	500000 Salaries - Admin	Expense	31,090.81
1/15/2025	WIRE	MODERN HR, INC.	PPE 01/11/2025	500100 Salaries - Recycling	Expense	36,815.75
1/15/2025	WIRE	MODERN HR, INC.	PPE 01/11/2025	500110 SB1383 Staff	Expense	4,694.42
1/15/2025	WIRE	MODERN HR, INC.	PPE 01/11/2025	501000 Benefits - Payroll Taxes	Expense	1,815.88
1/15/2025	WIRE	MODERN HR, INC.	PPE 01/11/2025	501005 Benefits - Workers Comp Ins	Expense	377.54
1/15/2025	WIRE	MODERN HR, INC.	PPE 01/11/2025	501010 Benefits - Retirement Employee	Expense	(9,344.34)
1/15/2025	WIRE	MODERN HR, INC.	PPE 01/11/2025	501030 Benefits - CPE Fee	Expense	885.70
1/16/2025	12741	BEN FREDIA CONSULTING	Inv# 0005330	100010 Wells Fargo Bank	Check	(997.00)
1/16/2025	12741	BEN FREDIA CONSULTING	Maintenance & Hosting: January 2025	502025 Website Support	Check	997.00
1/16/2025	12745	CYNDI URMAN	JANUARY 2025 EMPLOYEE EXPENSE REIMBURSEMENT	100010 Wells Fargo Bank	Check	(200.00)
1/16/2025	12745	CYNDI URMAN	JANUARY 2025 EMPLOYEE EXPENSE REIMBURSEMENT	503030 Office Supplies	Check	200.00
1/16/2025	12748	LANALERT, INC.	Inv# 1958	100010 Wells Fargo Bank	Check	(4,011.14)
1/16/2025	12748	LANALERT, INC.	Jan-25	502020 IT Support	Check	4,011.14
1/16/2025	12758	WELLS FARGO VENDOR FINANCIAL SERVICES LLC	INV# 5032745860CONTRACT# 450-014222-000	100010 Wells Fargo Bank	Check	(438.93)
1/16/2025	12758	WELLS FARGO VENDOR FINANCIAL SERVICES LLC	12/29/2024-01/28/2025	503035 Office Equipment Costs	Check	438.93
1/16/2025	12749	LOCKWORKS UNLIMITED	INV# 1250109269	100010 Wells Fargo Bank	Check	(60.00)
1/16/2025	12749	LOCKWORKS UNLIMITED	INV# 1250109269 JAN 2025 - MAR 2025	503035 Office Equipment Costs	Check	60.00
1/16/2025	12759	WHEELER PLAZA OWNERS' ASSOCIATION	Account# 7164420761245 San Carlos Avenue Unit E	100010 Wells Fargo Bank	Check	(375.41)
1/16/2025	12759	WHEELER PLAZA OWNERS' ASSOCIATION	HOA Dues February 2025	503010 Rent	Check	375.41
1/16/2025	12744	CW SILICON VALLEY LLC	INV# 32051003375	100010 Wells Fargo Bank	Check	(2,092.00)
1/16/2025	12744	CW SILICON VALLEY LLC	45658	503030 Office Supplies	Check	2,092.00
1/16/2025	12754	SUNBELT RENTALS	INV# 163455491-0001ACCT# 941520	100010 Wells Fargo Bank	Check	(3,741.91)
1/16/2025	12754	SUNBELT RENTALS	SOLIDS VAC 49HP PUMP	507015 Shoreway Facility Cost	Check	3,741.91
1/16/2025	12740	BEECHER ENGINEERING INC	INV# 1224-80	100010 Wells Fargo Bank	Bill Payment (Check)	(220.00)
1/16/2025	12740	BEECHER ENGINEERING INC	INV# 1224-80	505035 505035 Project Assessments	Bill Payment (Check)	220.00
1/16/2025	12742	COMMON GOAL CONSULTING GROUP, INC	INV# 006	100010 Wells Fargo Bank	Bill Payment (Check)	(150.00)

**SOUTH BAYSIDE WASTE MANAGEMENT AUTHORITY
CHECK DETAIL REPORT
JANUARY 2025**

DATE	NUM	NAME	MEMO/DESCRIPTION	ACCOUNT	TRANSACTION TYPE	AMOUNT
1/16/2025	12742	COMMON GOAL CONSULTING GROUP, INC	INV# 006	503025 503025 Tenant Improvements	Bill Payment (Check)	150.00
1/16/2025	12743	CW SILICON VALLEY LLC	INV# 32051003300	100010 Wells Fargo Bank	Bill Payment (Check)	(2,092.00)
1/16/2025	12743	CW SILICON VALLEY LLC	INV# 32051003300	503030 503030 Office Supplies	Bill Payment (Check)	2,092.00
1/16/2025	12747	Environmental and Energy Consulting	Inv# 3590	100010 Wells Fargo Bank	Bill Payment (Check)	(6,650.03)
1/16/2025	12747	Environmental and Energy Consulting	Inv# 3590	504000 504000 Legislative & Reg Advoca	Bill Payment (Check)	6,650.03
1/16/2025	12750	MRF DESIGNS LLC	INV# 005	100010 Wells Fargo Bank	Bill Payment (Check)	(5,900.00)
1/16/2025	12750	MRF DESIGNS LLC	INV# 005	507045 507045 MRF Equipment Maintena	Bill Payment (Check)	5,900.00
1/16/2025	12752	SAN MATEO COUNTY TAX COLLECTOR	Inv# 2024-2025 Parcel# 046-081-820	100010 Wells Fargo Bank	Bill Payment (Check)	(31,565.59)
1/16/2025	12752	SAN MATEO COUNTY TAX COLLECTOR	Inv# 2024-2025 Parcel# 046-081-820	507050 507050 Sewer Fees (property tax)	Bill Payment (Check)	712.50
1/16/2025	12752	SAN MATEO COUNTY TAX COLLECTOR	Inv# 2024-2025 Parcel# 046-081-820	507050 507050 Sewer Fees (property tax)	Bill Payment (Check)	30,853.09
1/16/2025	12753	SCAPES INC	INV# 68440	100010 Wells Fargo Bank	Bill Payment (Check)	(375.00)
1/16/2025	12753	SCAPES INC	INV# 68440	507015 507015 Shoreway Facility Cost	Bill Payment (Check)	375.00
1/16/2025	12755	TANNER PACIFIC INC	INV# 224-361	100010 Wells Fargo Bank	Bill Payment (Check)	(10,775.00)
1/16/2025	12755	TANNER PACIFIC INC	INV# 224-361	6001031 6001031 Underground Storage Ta	Bill Payment (Check)	10,775.00
1/16/2025	12756	ULINE INC	INV# 1866902593 ORDER# 25255096	100010 Wells Fargo Bank	Bill Payment (Check)	(367.18)
1/16/2025	12756	ULINE INC	INV# 1866902593 ORDER# 25255096	5060208 5060208 In-School Environmental	Bill Payment (Check)	367.18
1/16/2025	12757	WELLS FARGO	STATEMENT DATE: 12/27/**** ACCT# **** * 6145	100010 Wells Fargo Bank	Bill Payment (Check)	(3,852.49)
1/16/2025	12757	WELLS FARGO	STATEMENT DATE: 12/27/**** ACCT# **** * 6145	502025 502025 Website Support	Bill Payment (Check)	21.99
1/16/2025	12757	WELLS FARGO	STATEMENT DATE: 12/27/**** ACCT# **** * 6145	507035 507035 Education Center Operations	Bill Payment (Check)	13.99
1/16/2025	12757	WELLS FARGO	STATEMENT DATE: 12/27/**** ACCT# **** * 6145	503065 503065 Training	Bill Payment (Check)	30.00
1/16/2025	12757	WELLS FARGO	STATEMENT DATE: 12/27/**** ACCT# **** * 6145	503060 503060 Conferences & Meetings	Bill Payment (Check)	49.00
1/16/2025	12757	WELLS FARGO	STATEMENT DATE: 12/27/**** ACCT# **** * 6145	506025 506025 Curbside Battery Outreach	Bill Payment (Check)	381.64
1/16/2025	12757	WELLS FARGO	STATEMENT DATE: 12/27/**** ACCT# **** * 6145	5060206 5060206 Community Events	Bill Payment (Check)	8.00
1/16/2025	12757	WELLS FARGO	STATEMENT DATE: 12/27/**** ACCT# **** * 6145	506025 506025 Curbside Battery Outreach	Bill Payment (Check)	34.77
1/16/2025	12757	WELLS FARGO	STATEMENT DATE: 12/27/**** ACCT# **** * 6145	5060208 5060208 In-School Environmental Education	Bill Payment (Check)	124.72
1/16/2025	12757	WELLS FARGO	STATEMENT DATE: 12/27/**** ACCT# **** * 6145	503060 503060 Conferences & Meetings	Bill Payment (Check)	1,587.91
1/16/2025	12757	WELLS FARGO	STATEMENT DATE: 12/27/**** ACCT# **** * 6145	503030 503030 Office Supplies	Bill Payment (Check)	1,498.96
1/16/2025	12757	WELLS FARGO	STATEMENT DATE: 12/27/**** ACCT# **** * 6145	503005 503005 Bank Fees & Services	Bill Payment (Check)	101.51
1/16/2025	12760	WILLARD DANIEL DECKER JR	INV# 3146	100010 Wells Fargo Bank	Bill Payment (Check)	(2,350.00)
1/16/2025	12760	WILLARD DANIEL DECKER JR	INV# 3146	505035 505035 Project Assessments	Bill Payment (Check)	2,350.00
1/16/2025	12746	E-RECYCLING OF CALIFORNIA	LOAD DATE 11/25/24,12/04/24,12/06/24,12/09/24,12/11/24,12/13/24,12/16/24,12/18/24	100010 Wells Fargo Bank	Bill Payment (Check)	(2,536.44)
1/16/2025	12746	E-RECYCLING OF CALIFORNIA	ACCT# 143.013, 390.001 LOAD DATE 11/25/24,12/04/24,12/06/24,12/09/24,12/11/24,12/13/24,12/16/24,12/18/24	400400 400400 E-Recycling Revenue	Bill Payment (Check)	627.04
1/16/2025	12746	E-RECYCLING OF CALIFORNIA	ACCT# 143.013, 390.001 LOAD DATE 11/25/24,12/04/24,12/06/24,12/09/24,12/11/24,12/13/24,12/16/24,12/18/24	400400 400400 E-Recycling Revenue	Bill Payment (Check)	255.21
1/16/2025	12746	E-RECYCLING OF CALIFORNIA	ACCT# 143.013, 390.001 LOAD DATE 11/25/24,12/04/24,12/06/24,12/09/24,12/11/24,12/13/24,12/16/24,12/18/24	400400 400400 E-Recycling Revenue	Bill Payment (Check)	433.23
1/16/2025	12746	E-RECYCLING OF CALIFORNIA	ACCT# 143.013, 390.001 LOAD DATE 11/25/24,12/04/24,12/06/24,12/09/24,12/11/24,12/13/24,12/16/24,12/18/24	400400 400400 E-Recycling Revenue	Bill Payment (Check)	792.00
1/16/2025	12746	E-RECYCLING OF CALIFORNIA	ACCT# 143.013, 390.001 LOAD DATE 11/25/24,12/04/24,12/06/24,12/09/24,12/11/24,12/13/24,12/16/24,12/18/24	400400 400400 E-Recycling Revenue	Bill Payment (Check)	428.96
1/16/2025	12751	RECOLOGY SAN MATEO COUNTY	INV# 11/30/2024: FUEL CREDIT NOV 2024	100010 Wells Fargo Bank	Bill Payment (Check)	(35,772.41)
1/16/2025	12751	RECOLOGY SAN MATEO COUNTY	INV# 11/30/2024: FUEL CREDIT NOV 2024	6001031 6001031 Underground Storage Ta	Bill Payment (Check)	35,772.41
1/17/2025	WIRE	SOUTH BAYSIDE INDUSTRIES.	2024-11	100010 Wells Fargo Bank	Expense	(2,745,405.50)
1/17/2025	WIRE	SOUTH BAYSIDE INDUSTRIES.	2024-11	5070105 Disposal & Processing - OTHER	Expense	91,976.43
1/17/2025	WIRE	SOUTH BAYSIDE INDUSTRIES.	2024-11	5070105 Disposal & Processing - OTHER	Expense	(17,073.88)
1/17/2025	WIRE	SOUTH BAYSIDE INDUSTRIES.	2024-11	400350 Miscellaneous Revenue	Expense	1,968.16
1/17/2025	WIRE	SOUTH BAYSIDE INDUSTRIES.	2024-11	6001001 Facilities Improvements (SF049)	Expense	83,023.60
1/17/2025	WIRE	SOUTH BAYSIDE INDUSTRIES.	2024-11	6001001 Facilities Improvements (SF049)	Expense	11,981.59
1/17/2025	WIRE	SOUTH BAYSIDE INDUSTRIES.	2024-11	6001001 Facilities Improvements (SF049)	Expense	31,454.36
1/17/2025	WIRE	SOUTH BAYSIDE INDUSTRIES.	2024-11	507025 Credit Card Charges	Expense	13,083.23
1/17/2025	WIRE	SOUTH BAYSIDE INDUSTRIES.	2024-11	507015 Shoreway Facility Cost	Expense	33,447.23
1/17/2025	WIRE	SOUTH BAYSIDE INDUSTRIES.	2024-11	507005 Operator Compensation SBR	Expense	2,499,481.10
1/22/2025	WIRE	CIC		100010 Wells Fargo Bank	Expense	(254,749.56)
1/22/2025	WIRE	CIC	23008.008 - 12/01/2024-12/31/2024	6001031 Underground Storage Tank Projec	Expense	268,157.43
1/22/2025	WIRE	CIC	23008.008 - 12/01/2024-12/31/2024	200115 Retention Payable	Expense	13,407.87
1/23/2025	WIRE	MODERN HR, INC.	PPE 01/11/2025	100010 Wells Fargo Bank	Expense	(52,975.57)
1/23/2025	WIRE	MODERN HR, INC.	PPE 01/11/2025	500000 Salaries - Admin	Expense	23,800.00
1/23/2025	WIRE	MODERN HR, INC.	PPE 01/11/2025	500100 Salaries - Recycling	Expense	24,600.00
1/23/2025	WIRE	MODERN HR, INC.	PPE 01/11/2025	500110 SB1383 Staff	Expense	3,000.00
1/23/2025	WIRE	MODERN HR, INC.	PPE 01/11/2025	501000 Benefits - Payroll Taxes	Expense	749.39
1/23/2025	WIRE	MODERN HR, INC.	PPE 01/11/2025	501005 Benefits - Workers Comp Ins	Expense	267.28
1/23/2025	WIRE	MODERN HR, INC.	PPE 01/11/2025	501030 Benefits - CPE Fee	Expense	558.90

**SOUTH BAYSIDE WASTE MANAGEMENT AUTHORITY
CHECK DETAIL REPORT
JANUARY 2025**

DATE	NUM	NAME	MEMO/DESCRIPTION	ACCOUNT	TRANSACTION TYPE	AMOUNT
1/24/2025	WIRE	FIVE STAR BANK		100010 Wells Fargo Bank	Expense	(47,363.46)
1/24/2025	WIRE	FIVE STAR BANK	Transfer from SBWMA WF Bank	100015 Five Star Checking	Expense	47,363.46
1/24/2025	ACH	KAISER PERMANENTE		100010 Wells Fargo Bank	Expense	(3,534.35)
1/24/2025	ACH	KAISER PERMANENTE	KAISER FEBRUARY 2025	501020 Benefits - Medical	Expense	3,534.35
1/24/2025	ACH	ANTHEM BLUE CROSS		100010 Wells Fargo Bank	Expense	(14,115.42)
1/24/2025	ACH	ANTHEM BLUE CROSS	Group insurance - February 2025	501020 Benefits - Medical	Expense	14,115.42
		PRINCIPAL LIFE INSURANCE COMPANY				
1/27/2025	ACH	PRINCIPAL LIFE INSURANCE COMPANY		100010 Wells Fargo Bank	Expense	(2,296.86)
1/27/2025	ACH	PRINCIPAL LIFE INSURANCE COMPANY	45689	501035 Benefits - Guardian Life	Expense	2,296.86
		STERLING HSA				
1/28/2025	ACH	STERLING HSA	January 2025 HSA	100010 Wells Fargo Bank	Expense	(4,375.00)
1/28/2025	ACH	STERLING HSA	January 2025- Sterling HSA	501025 Benefits - Sterling HSA	Expense	4,375.00
1/28/2025	ACH	JOHN HANCOCK USA		100010 Wells Fargo Bank	Expense	(25,136.32)
1/28/2025	ACH	JOHN HANCOCK USA	EE Contribution PPE 12/05/2024	501010 Benefits - Retirement Employee	Expense	4,685.12
1/28/2025	ACH	JOHN HANCOCK USA	ER Contribution PPE PPE 12/05/2024	501015 Benefits - Retirement Employer	Expense	7,997.09
1/28/2025	ACH	JOHN HANCOCK USA	EE Contribution PPE 12/05/2024	501010 Benefits - Retirement Employee	Expense	5,462.30
1/28/2025	ACH	JOHN HANCOCK USA	ER Contribution PPE PPE 12/05/2024	501015 Benefits - Retirement Employer	Expense	6,991.81
1/28/2025	ACH	JOHN HANCOCK USA		100010 Wells Fargo Bank	Expense	(8,006.01)
1/28/2025	ACH	JOHN HANCOCK USA	ER Contribution PPE PPE 12/19/2024	501015 Benefits - Retirement Employer	Expense	8,006.01
		E-RECYCLING OF CALIFORNIA				
1/29/2025	12765	E-RECYCLING OF CALIFORNIA	Voided - LOAD DATE: 12/17/2024143.012	100010 Wells Fargo Bank	Check	-
1/29/2025	12765	E-RECYCLING OF CALIFORNIA	I2405873	400400 E-Recycling Revenue	Check	-
1/29/2025	12776	ULINE INC	Voided - INV# 187779577	100010 Wells Fargo Bank	Check	-
1/29/2025	12776	ULINE INC	INV# 187779577 IN SCHOOL PROGRAMS	5060208 In-School Environmental Education	Check	-
1/29/2025	12761	AT&T	Voided - Acct. #650-596-7146-704-9	100010 Wells Fargo Bank	Check	-
1/29/2025	12761	AT&T	Shoreway Facility cost; monthly service Jan 13th thru Feb 12th 2025	507015 Shoreway Facility Cost	Check	-
1/29/2025	12770	PATH FORWARD PARTNERS INC	Voided - INV# 3378	100010 Wells Fargo Bank	Check	-
1/29/2025	12770	PATH FORWARD PARTNERS INC	PROJECT ASSESSMENTS: 09/28/2024-01/03/2025	505035 Project Assessments	Check	-
1/29/2025	12774	SCAPES INC	Voided - Inv# 68455	100010 Wells Fargo Bank	Check	-
		SCAPES INC				
1/29/2025	12774	SCAPES INC	Shoreway Facility Cost- January 2025: Concrete Pad, Demo Soil	507015 Shoreway Facility Cost	Check	-
1/29/2025	12767	JOE LA MARIANA	Voided - EMPLOYEE EXPENSE REIMB: JAN-25	100010 Wells Fargo Bank	Check	-
1/29/2025	12767	JOE LA MARIANA	CONF & MEETINGS REIMB: JAN-25	503060 Conferences & Meetings	Check	-
1/29/2025	12767	JOE LA MARIANA	OFFICE SUPPLIES REIMB: JAN-25	503030 Office Supplies	Check	-
1/29/2025	12766	FORSIGHT CREATIONS	Voided - INV# 25-C0002	100010 Wells Fargo Bank	Check	-
1/29/2025	12766	FORSIGHT CREATIONS	Overhead and Various Site Signage	6001009 Facilities Improvements (SF072)	Check	-
		COUNTY OF SAN MATEO - SUSTAINABILITY DEPARTMENT				
1/29/2025	12764	COUNTY OF SAN MATEO - SUSTAINABILITY DEPARTMENT	Voided - INV# GISCCFY2425005	100010 Wells Fargo Bank	Check	-
1/29/2025	12764	COUNTY OF SAN MATEO - SUSTAINABILITY DEPARTMENT	RETHINK WASTE'S CONTRIBUTION TTO THE COMPOST IMPROVEMENT DIGITAL CAMPAIGN (2 OF 2)	502008 SB1383 Outreach & Education	Check	-
1/29/2025	12763	Comcast	Voided - Acct# 8155200330542640	100010 Wells Fargo Bank	Check	-
1/29/2025	12763	Comcast	Utilities; services from Jan 22 to Feb 21 2025	503020 Utilities & Phone	Check	-
		NORTHERN CALIFORNIA RECYCLING ASSOC				
1/29/2025	12769	NORTHERN CALIFORNIA RECYCLING ASSOC	Voided - INV# 1464	100010 Wells Fargo Bank	Check	-
		NORTHERN CALIFORNIA RECYCLING ASSOC				
1/29/2025	12769	NORTHERN CALIFORNIA RECYCLING ASSOC	2025 Gold Level Sponsorship	503070 Sponsorship & Donations	Check	-
		NORTHERN CALIFORNIA RECYCLING ASSOC				
1/29/2025	12769	NORTHERN CALIFORNIA RECYCLING ASSOC	2025 Gold Level Sponsorship Registration	503060 Conferences & Meetings	Check	-
		NORTHERN CALIFORNIA RECYCLING ASSOC				
1/29/2025	12769	NORTHERN CALIFORNIA RECYCLING ASSOC	2025 Gold Level Sponsorship Membership	503045 Professional dues & Memberships	Check	-
1/29/2025	12771	PG&E	Voided - ACCT# 9220945109-2	100010 Wells Fargo Bank	Check	-
1/29/2025	12771	PG&E	STATEMENT DATE: 01/16/2025 ACCT# 9220945109-2	503020 Utilities & Phone	Check	-
1/29/2025	12773	S.R. ROSE ENGINEERING INC	Voided - INV# RTW-102	100010 Wells Fargo Bank	Check	-
1/29/2025	12773	S.R. ROSE ENGINEERING INC	INV# RTW-102	505005 Facility Improvement Oversight	Check	-
		WHEELER PLAZA OWNERS' ASSOCIATION				
1/29/2025	12777	WHEELER PLAZA OWNERS' ASSOCIATION	Voided - Account# 7164420761245 San Carlos Avenue Unit E	100010 Wells Fargo Bank	Check	-
		MODERN HR, INC.				
1/29/2025	12777	MODERN HR, INC.	HOA Dues March 2025	503010 Rent	Check	-
1/29/2025	WIRE	MODERN HR, INC.		100010 Wells Fargo Bank	Expense	(66,709.60)
1/29/2025	WIRE	MODERN HR, INC.	PPE 01/25/2025	500000 Salaries - Admin	Expense	31,090.84
1/29/2025	WIRE	MODERN HR, INC.	PPE 01/25/2025	500100 Salaries - Recycling	Expense	37,661.02
1/29/2025	WIRE	MODERN HR, INC.	PPE 01/25/2025	500110 SB1383 Staff	Expense	4,694.42
1/29/2025	WIRE	MODERN HR, INC.	PPE 01/25/2025	501000 Benefits - Payroll Taxes	Expense	1,383.62
1/29/2025	WIRE	MODERN HR, INC.	PPE 01/25/2025	501005 Benefits - Workers Comp Ins	Expense	381.94
1/29/2025	WIRE	MODERN HR, INC.	PPE 01/25/2025	501010 Benefits - Retirement Employee	Expense	(9,387.94)
1/29/2025	WIRE	MODERN HR, INC.	PPE 01/25/2025	501030 Benefits - CPE Fee	Expense	885.70
1/29/2025	WIRE	MODERN HR, INC.	PPE 01/25/2025	500150 Salaries - Car Allowance	Expense	-
1/29/2025	WIRE	MODERN HR, INC.	PPE 01/25/2025	500200 Salaries - Opt Out Medical	Expense	-
1/29/2025	ACH	JOHN HANCOCK USA		100010 Wells Fargo Bank	Expense	(4,469.49)
1/29/2025	ACH	JOHN HANCOCK USA	EE Contribution PPE 12/19/2024	501010 Benefits - Retirement Employee	Expense	4,469.49
		AT&T				
1/31/2025	12779	AT&T	Acct. #650-596-7146-704-9	100010 Wells Fargo Bank	Check	(2,389.51)
1/31/2025	12779	AT&T	Shoreway Facility cost; monthly service Jan 13th thru Feb 12th 2025	507015 Shoreway Facility Cost	Check	2,389.51
1/31/2025	12781	Comcast	Acct# 8155200330542640	100010 Wells Fargo Bank	Check	(389.64)
1/31/2025	12781	Comcast	Utilities; services from Jan 22 to Feb 21 2025	503020 Utilities & Phone	Check	389.64
		COUNTY OF SAN MATEO - SUSTAINABILITY DEPARTMENT				
1/31/2025	12782	COUNTY OF SAN MATEO - SUSTAINABILITY DEPARTMENT	INV# GISCCFY2425005	100010 Wells Fargo Bank	Check	(20,000.00)
1/31/2025	12782	COUNTY OF SAN MATEO - SUSTAINABILITY DEPARTMENT	RETHINK WASTE'S CONTRIBUTION TTO THE COMPOST IMPROVEMENT DIGITAL CAMPAIGN (2 OF 2)	502008 SB1383 Outreach & Education	Check	20,000.00
1/31/2025	12783	E-RECYCLING OF CALIFORNIA	LOAD DATE: 12/17/2024143.012	100010 Wells Fargo Bank	Check	(89.18)
1/31/2025	12783	E-RECYCLING OF CALIFORNIA	I2405873	400400 E-Recycling Revenue	Check	(89.18)
1/31/2025	12784	FORSIGHT CREATIONS	INV# 25-C0002	100010 Wells Fargo Bank	Check	(15,000.00)
1/31/2025	12784	FORSIGHT CREATIONS	Overhead and Various Site Signage	6001009 Facilities Improvements (SF072)	Check	15,000.00
1/31/2025	12786	JOE LA MARIANA	EMPLOYEE EXPENSE REIMB: JAN-25	100010 Wells Fargo Bank	Check	(1,378.05)
1/31/2025	12786	JOE LA MARIANA	CONF & MEETINGS REIMB: JAN-25	503060 Conferences & Meetings	Check	214.70
1/31/2025	12786	JOE LA MARIANA	OFFICE SUPPLIES REIMB: JAN-25	503030 Office Supplies	Check	1,163.35
		NORTHERN CALIFORNIA RECYCLING ASSOC				
1/31/2025	12787	NORTHERN CALIFORNIA RECYCLING ASSOC	INV# 1464	100010 Wells Fargo Bank	Check	(3,240.00)
		NORTHERN CALIFORNIA RECYCLING ASSOC				
1/31/2025	12787	NORTHERN CALIFORNIA RECYCLING ASSOC	2025 Gold Level Sponsorship	503070 Sponsorship & Donations	Check	1,500.00
		NORTHERN CALIFORNIA RECYCLING ASSOC				
1/31/2025	12787	NORTHERN CALIFORNIA RECYCLING ASSOC	2025 Gold Level Sponsorship Registration	503060 Conferences & Meetings	Check	1,680.00
		NORTHERN CALIFORNIA RECYCLING ASSOC				
1/31/2025	12787	NORTHERN CALIFORNIA RECYCLING ASSOC	2025 Gold Level Sponsorship Membership	503045 Professional dues & Memberships	Check	60.00
1/31/2025	12788	PATH FORWARD PARTNERS INC	INV# 3378	100010 Wells Fargo Bank	Check	(5,500.17)
1/31/2025	12788	PATH FORWARD PARTNERS INC	PROJECT ASSESSMENTS: 09/28/2024-01/03/2025	505035 Project Assessments	Check	5,500.17

**SOUTH BAYSIDE WASTE MANAGEMENT AUTHORITY
CHECK DETAIL REPORT
JANUARY 2025**

DATE	NUM	NAME	MEMO/DESCRIPTION	ACCOUNT	TRANSACTION TYPE	AMOUNT
1/31/2025	12789	PG&E	ACCT# 9220945109-2	100010 Wells Fargo Bank	Check	(1,027.80)
1/31/2025	12789	PG&E	STATEMENT DATE: 01/16/2025 ACCT# 9220945109-2	503020 Utilities & Phone	Check	1,027.80
1/31/2025	12791	S.R. ROSE ENGINEERING INC	INV# RTW-102	100010 Wells Fargo Bank	Check	(4,637.79)
1/31/2025	12791	S.R. ROSE ENGINEERING INC	INV# RTW-102	505005 Facility Improvement Oversight	Check	4,637.79
1/31/2025	12792	SCAPES INC	Inv# 68455	100010 Wells Fargo Bank	Check	(2,205.00)
1/31/2025	12792	SCAPES INC	Shoreway Facility Cost- January 2025: Concrete Pad, Demo Soil	507015 Shoreway Facility Cost	Check	2,205.00
1/31/2025	12794	ULINE INC	INV# 187779577	100010 Wells Fargo Bank	Check	(137.61)
1/31/2025	12794	ULINE INC	INV# 187779577 IN SCHOOL PROGRAMS	5060208 In-School Environmental Educatio	Check	137.61
1/31/2025	12795	WHEELER PLAZA OWNERS' ASSOCIATION	Account# 7164420761245 San Carlos Avenue Unit E	100010 Wells Fargo Bank	Check	(375.41)
1/31/2025	12795	WHEELER PLAZA OWNERS' ASSOCIATION	HOA Dues March 2025	503010 Rent	Check	375.41
1/31/2025	12780	BROWNING FERRIS INDUSTRIES OF CA INC	Inv# 4278-100009324	100010 Wells Fargo Bank	Bill Payment (Check)	(480,840.81)
1/31/2025	12780	BROWNING FERRIS INDUSTRIES OF CA INC	Cust# 4-4278-1001002	5070102 5070102 Disposal & Processing -	Bill Payment (Check)	480,840.81
1/31/2025	12785	JOE LA MARIANA	December 2024 Employee Expense Reimbursement	100010 Wells Fargo Bank	Bill Payment (Check)	(835.11)
1/31/2025	12785	JOE LA MARIANA	December 2024 Employee Expense Reimbursement	503060 503060 Conferences & Meetings	Bill Payment (Check)	312.11
1/31/2025	12785	JOE LA MARIANA	December 2024 Employee Expense Reimbursement	503030 503030 Office Supplies	Bill Payment (Check)	395.00
1/31/2025	12785	JOE LA MARIANA	December 2024 Employee Expense Reimbursement	503055 503055 Cell Phones	Bill Payment (Check)	128.00
1/31/2025	12790	RECOLOGY BLOSSOM VALLEY ORGANICS-N	Inv# 200051: Disposal - BVON December 2024	100010 Wells Fargo Bank	Bill Payment (Check)	(392,327.37)
1/31/2025	12790	RECOLOGY BLOSSOM VALLEY ORGANICS-N	Inv# 200051: Disposal - BVON December 2024	5070103 5070103 Disposal & Processing -	Bill Payment (Check)	392,327.37
1/31/2025	12793	TANNER PACIFIC INC	INV# 225-039, INV# 224-475	100010 Wells Fargo Bank	Bill Payment (Check)	(51,692.50)
1/31/2025	12793	TANNER PACIFIC INC	INV# 225-039, INV# 224-475	6001031 6001031 Underground Storage Ta	Bill Payment (Check)	20,252.50
1/31/2025	12793	TANNER PACIFIC INC	INV# 225-039, INV# 224-475	6001031 6001031 Underground Storage Ta	Bill Payment (Check)	31,440.00
1/31/2025	12796	ZANKER ROAD RESOURCE MANAGEMENT LLC	Inv# 1220241298	100010 Wells Fargo Bank	Bill Payment (Check)	(219,374.10)
1/31/2025	12796	ZANKER ROAD RESOURCE MANAGEMENT LLC	Inv# 1220241299	5070104 5070104 Disposal & Processing -	Bill Payment (Check)	219,374.10
TOTAL 100010 WELLS FARGO BANK						(7,296,687.19)
GRAND TOTAL						(7,304,581.10)



STAFF REPORT

To: RethinkWaste Board Members
From: Cyndi Urman, Sr. Management Analyst/Clerk of the Board
Date: February 27, 2025 Board of Directors Meeting
Subject: Technical Consulting Contracts: June 2024 to December 2024

Recommendation

This is an informational item only and no action is required. This report was requested by the Board members.

Summary

The purpose of this report is to provide an update to the Board on the technical consulting contracts that have been issued. All contracts issued between June 2024 and December 2024 are listed in Attachment A for review.

Throughout a given calendar year, staff will update this listing two to four times per year with any new technical contracts issued.

If you have any questions on the attached listing of technical contracts, please contact Cyndi Urman

Attachments:

Attachment A – Technical Consulting Contracts – June 2024 to December 2024

Technical Consultant Contracts June to December 2024

<u>Vendor Name</u>	<u>Amount of Contract</u>	<u>Contract Type</u>	<u>Scope of Work</u>	<u>Date of Award</u>	<u>Contract Procedures Used</u>	<u>Budget Line Item</u>	<u>Budget Line Item Description</u>
Bay Area Cloud IT and Security, LLC	\$41,205.00	Vendor Agreement	SEC Camera System Upgrades	5/24/2024	Sole Source	600100	Capital Improvements
Tanner Pacific*	\$206,682.50	Professional Services Agreement	Construction Management UST Removal	6/28/2024	Sole Source	600100	Capital Improvements
Studio EM Graphic Design	\$3,000.94	Vendor Agreement	Graphic Design of the 2025-2034 Long Range Plan	6/24/2024	Sole Source	506005	Long Range Plan
Pen Media LLC*	\$94,964.00	Vendor Agreement	Audio Visual Design and Implementation for new RethinkWaste Office	6/28/2024	Sole Source	600100	Capital Improvements
Arc Construction	\$30,000.00	Vendor Agreement	Office Move and Furniture Disassembly	7/1/2024	Sole Source	600100	Capital Improvements
CIC*	\$304,528.40	Change Order to Construction Services Agreement	Underground Storage Tank Dewatering Change Order	6/26/2024	RFP	600100	Capital Improvements
ForSight Creations	\$1,350.00	Change Order to Professional Services Agreement	Staff request to increase the signage size in the original agreement	7/10/2024	Sole Source	600100	Capital Improvements
Arc Construction	\$11,000.00	Vendor Agreement Amendment #1	Office Move and Furniture Disassembly	7/1/2024	Sole Source	600100	Capital Improvements
Path Forward Partners	\$10,000.00	Professional Services Agreement	Permit Assistance and Effluent Sampling and Analysis	7/16/2024	Sole Source	505035	Shoreway Project Assessments
HF&H Consulting	\$16,500.00	Professional Services Agreement	2024-2025 Rate Survey and Financial Analysis Services	7/22/2024	Sole Source	505000	Rate Review
Lyngso	\$400/Month	Lease Amendment #1	Four Additional Parking Spaces for a total of 12 at \$1200 per month until 12/31/2024	7/22/2024	Sole Source	507015	Shoreway Facility Cost
MRF Designs LLC	\$46,240.00	Professional Services Agreement	2024 Organics to Energy Processing System Equipment Assessment and Design Improvements	7/31/2024	Sole Source	505035	Shoreway Project Assessments
T3 Engineering	\$37,440.00	Professional Services Agreement	2024 Technical Engineering Consulting MRF Automation Project	9/1/2024	Sole Source	505035	Shoreway Project Assessments
City Wide Janitorial Services	\$2,092 /Month	Professional Services Agreement	San Carlos Ave. Janitorial Services	9/19/2024	RFQ	503020	Utilities
Studio EM Graphic Design	\$982.13	PO	Rethinker Newsletter for Fall/Winter 2024-25	9/24/2024	Sole Source	506020-04	Member Agency/Rate Payer Education
KlarSheild	\$1,280.00	PO	Film Installation on Administrative Office Windows	9/25/2024	RFQ	503025	Office Tennant Improvements
Lockworks Unlimited, Inc.	\$4,768.05	Vendor Agreement	Installation of the Galaxy Control System for Access to 1245 San Carlos Ave. Back Door	8/27/2024	RFQ	600100	Capital Improvements
Lockworks Unlimited, Inc.	4,101.25	Vendor Agreement	Installation of the Galaxy Control System for Access to 1245 San Carlos Ave. Front Door	10/17/2024	RFQ	600100	Capital Improvements
Arc Construction	\$9,370.00	Vendor Agreement Amendment #2	Office Move and Furniture Disassembly	7/1/2024	Sole Source	600100	Capital Improvements
S.R. Engineering (Sean Rose)	\$60,000.00	Professional Services Agreement	On Call Project Management and Consulting Services	9/27/2024	Sole Source	505035	Facility Master Planning Project
Concrete Restoration*	\$483,974.00	Construction Services Agreement	2024 Transfer Station Floor Repair Project	10/25/2024	RFP	600100	Capital Improvements

Technical Consultant Contracts June to December 2024

<u>Vendor Name</u>	<u>Amount of Contract</u>	<u>Contract Type</u>	<u>Scope of Work</u>	<u>Date of Award</u>	<u>Contract Procedures Used</u>	<u>Budget Line Item</u>	<u>Budget Line Item Description</u>
DTE Networks	\$3,102.19	Professional Services Agreement	Installation and materials for 9 additional work space drops	10/7/2024	Sole Source	600100	Admin Offices Improvements
ForSight Creations	\$34,815.00	Public Project Agreement	Installation of Painted Ground Graphics for Wayfinding at Shoreway	10/17/2024	Sole Source	600100	Capital Improvements
ForSight Creations	\$24,972.00	Public Project Agreement	Installation of Painted Ground Graphics for Wayfinding at Shoreway	1/10/2025	Sole Source	600100	Capital Improvements
Environmental and Energy Consulting EEC*	\$156,000.00	Professional Services Agreement	2-year contract for Legislative and Regulatory Services	11/22/2024	Sole Source	504000	Legislative and Regulatory Services
Common Goal Consulting	\$4,200.00	Professional Services Agreement Amendment #1	Assist in the development of construction phasing schedules and estimates of probable construction costs	12/5/2024	Sole Source	505005	Facility Improvement Oversight
Common Goal Consulting	\$3,300.00	Professional Services Agreement Amendment #1	Staff Training	12/5/2024	Sole Source	503065	Training
ForSight Creations	\$60,000.00	Public Project Agreement	Shoreway Environmental Center Overhead Signs	12/4/2024	Sole Source	600100	Capital Improvements

Competitive Procurement includes selecting contractors resulting from Requests for Proposals (RFP), Requests for Qualifications (RFQ), obtaining multiple bids/proposals and/or obtaining a sole source solicitation of bids/contracts and subsequent contract negotiations. adopted by the Board of Directors with the passage of a resolution.

STAFF UPDATE

2024-2025 RethinkWaste Meeting Planning Guide

- *Board Meetings*
- *Finance Committee Meetings*
- *TAC Meetings*
- *Legislative Committee Meetings*
- *Pub Ed Committee Meetings*
- *Zero-Waste Committee Meetings*
- *Agency-Sponsored Community Events*

2025 Meetings Schedule*

March 2025

3: Legislative Committee

27: Board and TAC Retreat 12 to 4PM at the Belmont Sports Complex

April 2025

7: Legislative Committee

TBD: Finance Committee Meeting

- Discussion/review of options for future site cap projects funding

24: Board Meeting

- Presentation of 2024 Annual Report
- Discussion on adding Social Security Benefits for Agency Employees
- Approval of Contract with Beecher Engineering for \$77,000 to design site ZEV electrical infrastructure plan
- Approval of next gen Organics to Energy processing equipment/operations
- Approval of Consulting Contract with Sean Rose for ZEV/multiple projects management
- Approval of Contract with HF&H Consultants for Reserve Fund Analysis
- Approval of Contract with for 2025 Public Outreach Campaigns
- Approval of a contract with New Aspect Financial for retirement benefits analysis and recommendations
- Resolution Approving plans and specifications and authorizing staff to Release Notice inviting bids for the Paving project in the Roll Off Truck Area and the East Side of the Material Recovery Facility to allow for more Shoreway storage area
- Resolution Approving plans and specifications and authorizing staff to Release Notice inviting bids for the Transfer Station Floor Repair South Side and Tunnel concrete coping repair project
- Resolution Approving plans and specifications and authorizing staff to Release Notice inviting bids for the Shoreway Environmental Monument Signage

26: Earth Day at Shoreway

May 2025

5: Legislative Committee

8: TAC Meeting

TBD: Zero Waste Committee

22: Board Meeting

June 2025

2: Legislative Committee

10: Finance Committee Meeting

- Mid-Year Budget Review
- Governmental Accounting Organization of the US, Internal control Template Review

26: Board Meeting

- FY 2025 Budget Review
- Mid-Session Legislative Update
- RSS Internal Audit—Findings and Recommendations report

July 2025

1: Legislative Committee

10: TAC Meeting

24: Board Meeting

August 2025

No Board Meeting

September 2025

2: Legislative Committee

9: Finance Committee Meeting

11: TAC Meeting

18: Board Meeting (Third Thursday)

- Approval of Annual Contractor Applications

October 2025

7: Legislative Committee

14: Finance Committee Meeting

23: Board Study Session

- Review of DRAFT FY2026 Budget—Operating Revenue, Expenses, Reserves
- Review of DRAFT FY 2026 Capital Improvement Plan and 5 yr. look ahead

November 2025

4: Legislative Committee

20: Board Meeting (Third Thursday) ~ Annual Holiday Thank You Lunch

- Approval of FY2026 Budget
- 2025 Legislative Session Recap
- Approval of Contract for Annual Operations and Financial Auditing

December 2025

No Board Meeting